

USER MANUAL



OmniPoint™

Universal Transmitter



WWW.MICROWATT.COM 1.888.388.1592

mwsales@microwatt.com

Honeywell

CONTENTS

| | |
|---|-----------|
| Chapter 1 - Introduction | 5 |
| 1.1 Product Description | 5 |
| 1.2 Safety | 6 |
| 1.3 Certifications and Approvals | 8 |
| Chapter 2 - Hardware | 9 |
| 2.1 What's in a Full System Box | 9 |
| 2.2 Transmitter overview | 10 |
| 2.3 Sensor & Local Hart Interface | 12 |
| 2.3.1 Sensor Specifications | 13 |
| 2.3.2 EC Sensor Cross Sensitivity | 14 |
| 2.3.3 Sensors Warm Up Time | 15 |
| 2.3.4 Sensor Module Distances | 16 |
| Chapter 3 - Installation | 18 |
| 3.1 Mounting the Transmitter | 18 |
| 3.2 Wiring the Transmitter | 20 |
| 3.2.1 General Wiring Considerations | 22 |
| 3.2.2 Transmitter Distances | 24 |
| 3.2.3 Sensor wiring For Terminal Block 2 (TB2) | 29 |
| 3.2.4 Sensor Wiring | 30 |
| 3.2.5 Optima Wiring | 30 |
| 3.2.6 Remote reset connection and remote distance | 32 |
| 3.3 Relays | 34 |
| 3.3.1 Relay Settings | 35 |
| 3.4 4-20mA Output, Common Connections, and Power Settings | 36 |
| Chapter 4 - Device Operation | 37 |
| 4.1 User interface overview | 37 |
| 4.1.1 Light Ring | 38 |
| 4.1.2 Main Menu options | 38 |
| 4.2 Initial Setup | 39 |
| 4.3 Calibration | 40 |

| | | |
|--|---|-----------|
| 4.3.1 | Zero Calibration | 40 |
| 4.3.2 | Span Calibration | 42 |
| 4.3.3 | Zero and Span Calibration for XP/XPIS Sensors | 44 |
| 4.3.4 | Cross Calibration for XP Combustible Gas Sensor | 44 |
| 4.4 | Bump Test | 48 |
| 4.5 | Reset Alarm | 49 |
| 4.6 | Settings | 50 |
| 4.6.1 | General | 50 |
| 4.6.2 | Sensors | 50 |
| 4.6.3 | Inhibit & Fault | 51 |
| 4.6.4 | HART (FSK) Communication | 52 |
| 4.6.5 | MODBUS RTU Communication | 52 |
| 4.6.6 | Security | 52 |
| 4.7 | View Information | 54 |
| 4.8 | Channel Setting | 56 |
| 4.9 | Inhibit | 58 |
| 4.10 | Transmitter Menu Navigation | 59 |
| Chapter 5 - Maintenance | | 60 |
| 5.1 | Maintenance Menu | 60 |
| 5.2 | Replace an XPIS sensor | 61 |
| 5.3 | Replace an XP sensor | 62 |
| 5.4 | Replace an Optima sensor | 63 |
| Chapter 6 - Additional Info | | 64 |
| 6.1 | Modbus Register Map | 64 |
| 6.2 | Warning Information | 68 |
| 6.3 | Fault Information | 69 |
| 6.4 | Information messages | 70 |
| 6.5 | Technical Specifications | 72 |
| 6.6 | HART | 74 |
| 6.6.1 | Local HART Module | 74 |
| 6.6.2 | Device Specific Command-List | 76 |

| | |
|---|-----------|
| 6.7 Ordering | 77 |
| Chapter 7 - Mobile App | 79 |
| 7.1 Install the OmniPoint App | 79 |
| 7.2 Sign Up | 80 |
| 7.3 Register a Device & Company | 81 |
| 7.4 Bluetooth Pairing | 82 |
| 7.5 Mobile App Menu Navigation | 83 |
| 7.6 Bluetooth Hardware and Wiring | 84 |
| 7.7 Security Guide | 85 |
| 7.8 Contact Us | 86 |

1 INTRODUCTION

1.1 Product Description

The OmniPoint™ transmitter is a comprehensive gas detection solution designed to operate in hazardous locations and support multiple sensors in detecting toxic, oxygen, and flammable gas hazards. OmniPoint utilizes multiple sensor technologies to meet diverse gas detection challenges in various global industries. Full color, touch key interface, and optional Bluetooth-enabled operation make setup and maintenance intuitive. Support for up to three sensors makes OmniPoint flexible and scalable to meet your safety requirements.

1.2 Safety

 **WARNING**

RISK OF IGNITION OR ELECTRIC SHOCK

- Install in accordance with local electrical codes.
- Follow the warnings and requirements on the junction box for proper seals in the conduit as required.
- To reduce the risk of ignition in hazardous atmospheres, conduit runs must have a seal fitting connected within 18in. of the enclosure (Only for XPIS Sensor).
- Do not open in an explosive atmosphere.
- Do not open or separate when energized.
- Potential electrostatic charging hazard.

RISK OF ELECTROSTATIC DISCHARGE

- Clean the product only with a damp cloth.

RISK OF EXPLOSION

- High off-scale readings may indicate an explosive gas concentration

 **CAUTION**

RISK OF IGNITION

- To reduce the risk of ignition in hazardous atmospheres, disconnect the equipment from the supply circuit before opening the enclosure. Keep tightly closed when in operation.
- Intrinsic safety-related circuits are limited to overvoltage category III or less.

RISK OF INJURY, IMPROPER OPERATION, EQUIPMENT DAMAGE, AND INVALIDATION OF WARRANTY

- Install in accordance with local electrical codes.
- Relevant standards must be followed to maintain the overall certification of the detector.
- Only use with Honeywell replacement parts and accessories.
- Never open system devices under power unless the area is known to be non-hazardous.
- The internal grounding terminal shall be used as the equipment grounding means. The external terminal is only a supplemental bonding connection where local authorities permit or require it.
- Periodic checks are recommended to verify the safety and integrity of the system.
- For optimal performance, periodically zero the sensor in a normal atmosphere (20.9% v/v O₂) that is free of hazardous gases.
- As some test gases are hazardous, exhaust the flow housing outlet to a safe area.
- All unused and used cable/conduit entries must be sealed with a suitable certified sealing plug and cable gland.
- Use only certified 3/4" or M25 cable glands for installation.
- Use copper conductors only.

Special conditions for safe use of the local HART interface intrinsically safe circuits:

- The flameproof joints are not intended to be repaired.
- The device does not meet the 500V rms dielectric requirement between the IS circuit and the earth.
- For installations in which both the C_i and L_i of the intrinsically safe apparatus exceed 1% of the C_o and L_o parameters of the associated apparatus (excluding the cable), then 50% of C_o and L_o parameters are applicable and shall not be exceeded, i.e., the C_i of the device plus the C of the cable must be less than or equal to 50% of the C_o of the associated apparatus. The L_i of the device plus the L of the cable must be less than or equal to 50% of the L_o of the associated apparatus.
- For circuits connected to the HART interface in which the capacitance and inductance exceed 1% of the permitted values, the maximum allowed capacitance is limited to 600nF for group IIC and 1uF for group IIC.
- The connection to the HART circuit shall be rated at least IP 6X.
- Only wipe the enclosure and window with a soft, damp cloth.

1.3 Certifications and Approvals

Hazardous Area Approvals (Transmitter/Sensor Dependent)

UL cUL classified: UL 1203, UL 913, UL 61010-1, CSA C22.2 No. 25, CSA C22.2 No. 30, CSA C22.2 No. 60079-0, CSA C22.2 No. 60079-11, CAN/CSA-C22.2 No. 61010-1-12;

Class I, Division 1, Groups A, B, C, & D T5;

Class II, Division 1, Groups F & G T4A



EU Directive 2012/19/EU: Waste Electrical and Electronic Equipment (WEEE) This symbol indicates that the product must not be disposed of as general industrial or domestic waste. This product should be disposed of through suitable WEEE disposal facilities. For more information about the disposal of this product, contact your authority, distributor, or manufacturer.

2 HARDWARE

2.1 What's in a Full System Box

| | | |
|------------------------------|-------------------|----------------|
| 1 Quick Reference Guide | 3 Terminal blocks | 1 Screwdriver |
| 1 M22 plug or BLE (optional) | 1 Calibration Cap | 1 Allen Wrench |
| 3 Plugs 3/4" NPT or M25 | 1 Transmitter | |

2.2 Transmitter overview

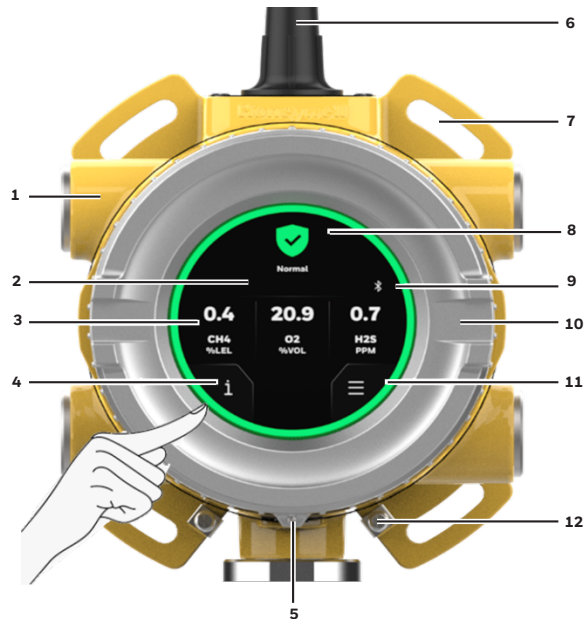

| | | | |
|----|--|----|--|
| 1 | Five M25 or 3/4"NPT entries (Antenna port excluded). | 2 | Full-color TFT LCD with four touch keys. |
| 3 | Gas Readings, Gas type, Unit. | 4 | Information menu: Event history, Calibration history, System Date and Time, Channel. |
| 5 | Top enclosure set screw. | 6 | Bluetooth Antenna (optional). |
| 7 | Elliptical racetrack-screw holes to maximize the fit of four M8 screws. | 8 | The LED light and icon show the transmitter's current status. |
| 9 | Display indicator icons: -Installed option module icons. -Calibration/bump overdue icons. -Sensor changed icon. | 10 | Ergonomic bevel and curved design for a more straightforward operation. |
| 11 | Main menu: Test & Calibration, Settings, Maintenance, Inhibit. | 12 | Earth/ground point. |

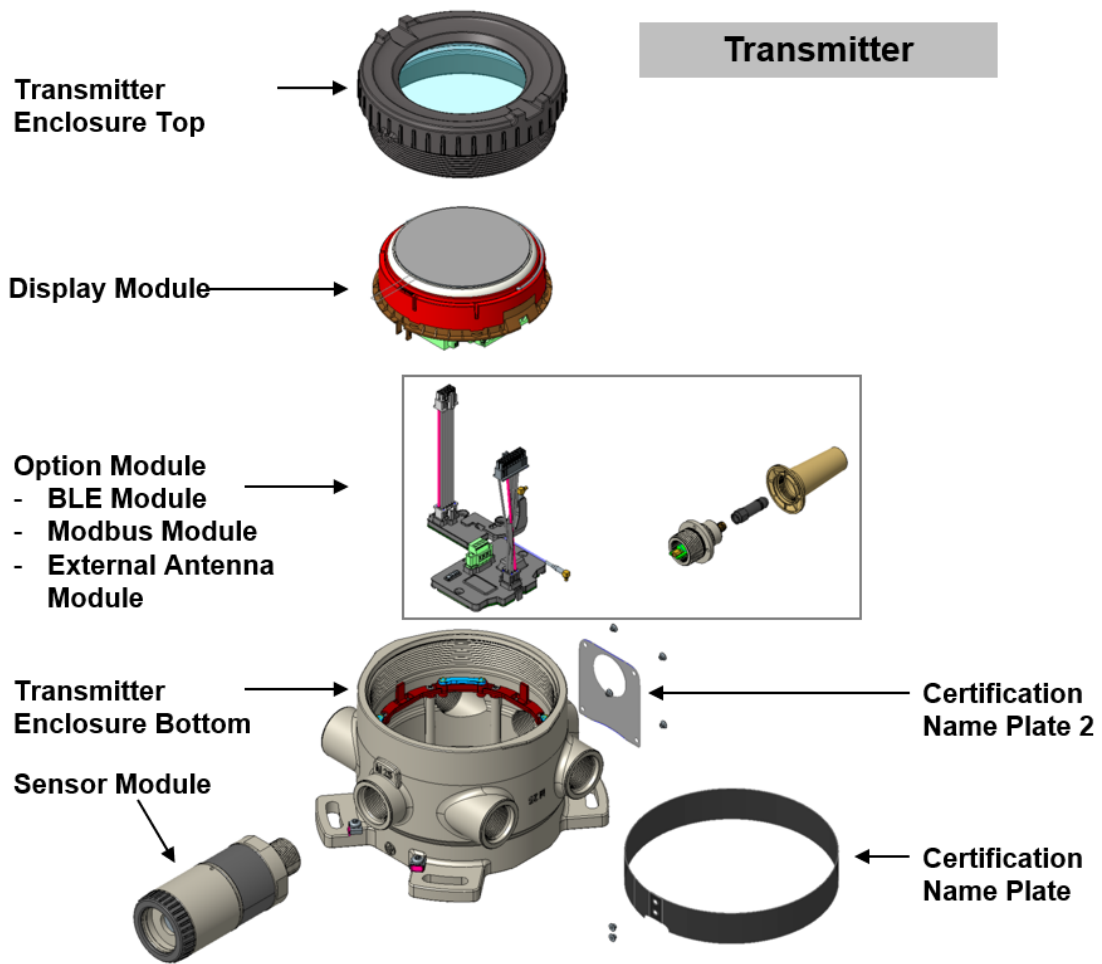

2.3 Sensor & Local Hart Interface

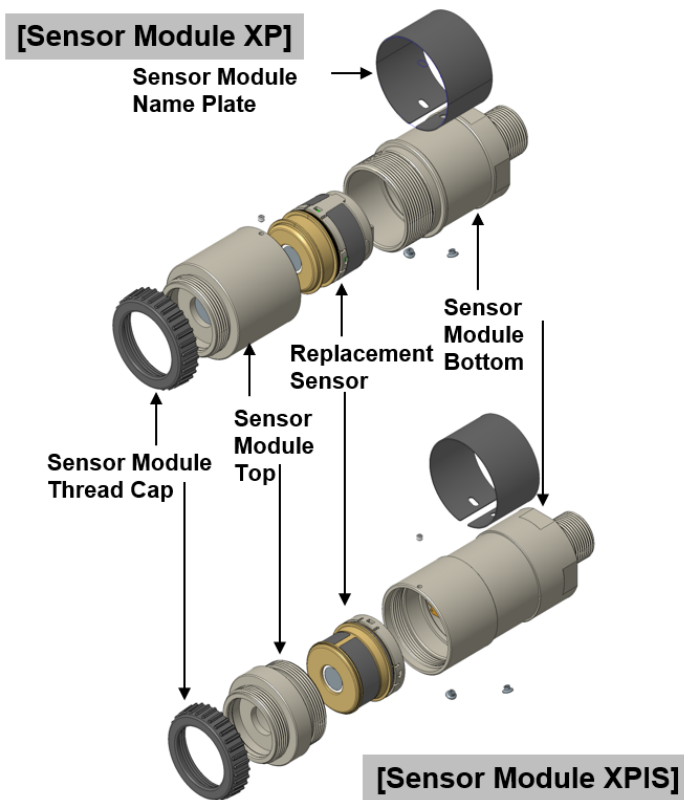

2.3.1 Sensor Specifications

| XPIS sensor | | | | | | | | | | | | | | | | | | |
|-------------|-------------------|---------------|-----------------------------|---------------|------------|------------------------------|-------------------------|-----------------------|--------------|-----------------------|--------------|-------------------|-----------------------------|-------------------|--------------------------|---------------------------|---|-------------------------------|
| Sensor type | Gas | Cartridge P/N | Selectable Full Scale Range | Default Range | Resolution | Lower Detectable Limit (LDL) | Lowest AlarmLevel (LAL) | Default Alarm 1 Level | Alarm 1 Type | Default Alarm 2 Level | Alarm 2 Type | Primary Cal Gas | Selectable Cal Gas Range | Default Cal Point | *Response time (T50) sec | *Response time (T90) sec* | **Accuracy (Reading or % of applied gas which is the greater) | Operating Temperature |
| NH3 | Ammonia | OPT-R1S-AM1 | 50 to 200 ppm | 200 ppm | 1 ppm | 6 ppm | 20 ppm | 50 ppm | Rising | 100 ppm | Rising | Ammonia | 30 to 70% of selected range | 100 ppm | < 30 | < 180 | < ±10 ppm or ±20% | -20 to +40 °C / -4 to 104 °F |
| NH3 (High) | Ammonia | OPT-R1S-AM2 | 200 to 1000 ppm | 1000 ppm | 1 ppm | 30 ppm | 100 ppm | 200 ppm | Rising | 500 ppm | Rising | Ammonia | 30 to 70% of selected range | 500 ppm | < 30 | < 180 | < ±50 ppm or ±20% | -20 to +40 °C / -4 to 104 °F |
| CO | Carbon Monoxide | OPT-R1S-CO1 | 100 to 500 ppm | 300 ppm | 1 ppm | 5 ppm | 15 ppm | 100 ppm | Rising | 200 ppm | Rising | Carbon Monoxide | 30 to 70% of selected range | 100 ppm | < 10 | < 20 | < ±25 ppm or ±20% | -40 to +55 °C / -40 to 131 °F |
| Cl2 | Chlorine | OPT-R1S-CL1 | 5.00 ppm (Fixed) | 5.00 ppm | 0.01 ppm | 0.15 ppm | 0.50 ppm | 1.00 ppm | Rising | 2.00 ppm | Rising | Chlorine | 30 to 70% of selected range | 2.00 ppm | < 20 | < 60 | < ±0.25 ppm or ±20% | -20 to +55 °C / -4 to 131 °F |
| H2S | Hydrogen Sulphide | OPT-R1S-HS1 | 10.0 to 50.0 ppm | 15.0 ppm | 0.1 ppm | 1.0 ppm | 3.0 ppm | 5.0 ppm | Rising | 10.0 ppm | Rising | Hydrogen Sulphide | 30 to 70% of selected range | 10.0 ppm | < 10 | < 20 | < ±2.5 ppm or ±20% | -40 to +65 °C / -40 to 149 °F |
| H2S (High) | Hydrogen Sulphide | OPT-R1S-HS2 | 50 to 500 ppm | 100 ppm | 1 ppm | 1 ppm | 5 ppm | 20 ppm | Rising | 50 ppm | Rising | Hydrogen Sulphide | 30 to 70% of selected range | 50 ppm | < 10 | < 20 | < ±25 ppm or ±20% | -40 to +65 °C / -40 to 149 °F |
| O2 | Oxygen | OPT-R1S-OX1 | 25.0 %vol (Fixed) | 25.0 %vol | 0.1 %vol | 0.2 %vol | 5.0 %vol | 23.5 %vol | Rising | 19.5 %vol | Falling | Oxygen | 20.9 %vol (Fixed) | 20.9 %vol | T20 : < 10 | < 15 | < ±0.5 %Vol | -40 to +60 °C / -40 to 140 °F |
| SO2 | Sulphur Dioxide | OPT-R1S-SO1 | 5.0 to 20.0 ppm | 15.0 ppm | 0.1 ppm | 0.6 ppm | 2.0 ppm | 5.0 ppm | Rising | 10.0 ppm | Rising | Sulphur Dioxide | 30 to 70% of selected range | 5.0 ppm | < 10 | < 20 | < ±1 ppm or ±20% | -40 to +65 °C / -40 to 149 °F |

| XP sensor | | | | | | | | | | | | | | | | | | |
|---------------|------------|--|-----------------------------|---------------|------------|------------------------|-------------------------|-----------------------|--------------|-----------------------|--------------|-----------------|-----------------------------|-------------------|--------------------------|--------------------------|---|-------------------------------|
| Sensor type | Gas | Cartridge P/N | Selectable Full Scale Range | Default Range | Resolution | Lower Detectable Limit | Lowest AlarmLevel (LAL) | Default Alarm 1 Level | Alarm 1 Type | Default Alarm 2 Level | Alarm 2 Type | Primary Cal Gas | Selectable Cal Gas Range | Default Cal Point | *Response time (T50) sec | *Response time (T90) sec | **Accuracy (Reading or % of applied gas which is the greater) | Operating Temperature |
| FL CAT | Flammables | OPT-R1X-FL1 (UL) OPT-R1X-FL2 (ATEX) | 20 to 100 %LEL | 100 %LEL | 1 %LEL | 3 %LEL | 5 %LEL | 20 %LEL | Rising | 50 %LEL | Rising | Methane | 30 to 70% of selected range | 50 %LEL | < 20 | < 60 | < ±10%FS or ±20% | -40 to +75 °C / -40 to 167 °F |
| CH4 IR - LEL | Methane | OPT-R1X-ME1 (UL) OPT-R1X-ME2 (ATEX) | 20 to 100 %LEL | 100 %LEL | 1 %LEL | 3 %LEL | 5 %LEL | 20 %LEL | Rising | 50 %LEL | Rising | Methane | 30 to 70% of selected range | 50 %LEL | < 20 | < 60 | < ±10%FS or ±20% | -40 to +75 °C / -40 to 167 °F |
| C3H8 IR - LEL | Propane | OPT-R1X-PR1 (UL) OPT-R1X-PR2 (ATEX) | 20 to 100 %LEL | 100 %LEL | 1 %LEL | 3 %LEL | 5 %LEL | 20 %LEL | Rising | 50 %LEL | Rising | Propane | 30 to 70% of selected range | 50 %LEL | < 20 | < 60 | < ±10%FS or ±20% | -40 to +75 °C / -40 to 167 °F |

Notes:

* Response time was measured at room temperature.

** The accuracy was measured above -20°C of operating temperature. The accuracy for operation between -20°C and -40°C was ±30% applied.

***Typically standard temperature range for EC sensors is -20°C to +55°C. -20°C to +40°C for Ammonia sensors.

****Extended temperature ranges for EC sensors are -40°C to -20°C and +55 to +65°C.

*****Operating the EC sensors at extended temperature ranges for a prolonged period exceeding 12 hours may cause deterioration in sensor performance and shorter sensor life.

2.3.2 EC Sensor Cross Sensitivity

| Gas type | Part number | Gas Type Applied | Concentration | Unit | Reading | Unit |
|-------------------|-------------|-------------------|---------------|----------------|---------------------------|---------|
| NH3 (Low range) | OPT-R1S-AM1 | Alcohols | 1000 | ppm | 0 | ppm NH3 |
| | | Carbon Monoxide | 100 | ppm | 0 | ppm NH3 |
| | | Chlorine | 5 | ppm | 0 | ppm NH3 |
| | | Nitrogen Dioxide | 10 | ppm | 0 | ppm NH3 |
| | | Sulfur Dioxide | 20 | ppm | -40 | ppm NH3 |
| | | Hydrogen | 3000 | ppm | 0 | ppm NH3 |
| | | Hydrogen Sulfide | 20 | ppm | 20 | ppm NH3 |
| NH3 (High range) | OPT-R1S-AM2 | Alcohols | 1000 | ppm | 0 | ppm NH3 |
| | | Carbon Monoxide | 100 | ppm | 0 | ppm NH3 |
| | | Chlorine | 5 | ppm | 0 | ppm NH3 |
| | | Nitrogen Dioxide | 10 | ppm | 0 | ppm NH3 |
| | | Sulfur Dioxide | 20 | ppm | -40 | ppm NH3 |
| | | Hydrogen | 3000 | ppm | 0 | ppm NH3 |
| | | Hydrogen Sulfide | 20 | ppm | 20 | ppm NH3 |
| CO | OPT-R1S-CO1 | Acetone | 1000 | ppm | 0 | ppm CO |
| | | Acetylene | 40 | ppm | 80 | ppm CO |
| | | Ammonia | 100 | ppm | 0 | ppm CO |
| | | Carbon Monoxide | 100 | ppm | 100 | ppm CO |
| | | Chlorine | 2 | ppm | 0 | ppm CO |
| | | Ethanol | 2000 | ppm | 3 | ppm CO |
| | | Ethylene | 100 | ppm | 85 | ppm CO |
| | | Hydrogen | 100 | ppm | 20 | ppm CO |
| | | Hydrogen Sulfide | 25 | ppm | 0 | ppm CO |
| | | Iso-Propanol | 200 | ppm | 0 | ppm CO |
| | | Nitrogen Monoxide | 50 | ppm | 8 | ppm CO |
| | | Nitrogen Dioxide | 800 | ppm | 20 | ppm CO |
| | | Sulfur Dioxide | 50 | ppm | 0.5 | ppm CO |
| | | Cl2 (Low range) | OPT-R1S-CL1 | Carbon Dioxide | 20000 | ppm |
| Hydrogen Chloride | 9 | | | ppm | 1.25 | ppm Cl2 |
| Hydrogen Sulfide | 25 | | | ppm | -16.3 | ppm Cl2 |
| Nitrogen Dioxide | 50 | | | ppm | 1.25 (transient) | ppm Cl2 |
| Sulfur Dioxide | 50 | | | ppm | 9.1 | ppm Cl2 |
| H2S (Low range) | OPT-R1S-HS1 | Ammonia | 50 | ppm | 0 | ppm H2S |
| | | Carbon Monoxide | 100 | ppm | <2 | ppm H2S |
| | | Carbon Dioxide | 5000 | ppm | 1 | ppm H2S |
| | | Chlorine | 0.5 | ppm | 0 | ppm H2S |
| | | Ethylene | 100 | ppm | 0 | ppm H2S |
| | | Hydrogen | 100 | ppm | 0 | ppm H2S |
| | | Hydrogen Sulfide | 10 | ppm | 10 | ppm H2S |
| | | Nitrogen Monoxide | 25 | ppm | 0 | ppm H2S |
| | | Nitrogen Dioxide | 3 | ppm | 0 | ppm H2S |
| Sulfur Dioxide | 2 | ppm | 0 | ppm H2S | | |
| H2S (High range) | OPT-R1S-HS2 | Ammonia | 50 | ppm | 0 | ppm H2S |
| | | Carbon Monoxide | 100 | ppm | <2 | ppm H2S |
| | | Carbon Dioxide | 5000 | ppm | 1 | ppm H2S |
| | | Chlorine | 0.5 | ppm | 0 | ppm H2S |
| | | Ethylene | 100 | ppm | 0 | ppm H2S |
| | | Hydrogen | 100 | ppm | 0 | ppm H2S |
| | | Hydrogen Sulfide | 10 | ppm | 10 | ppm H2S |
| | | Nitrogen Monoxide | 25 | ppm | 0 | ppm H2S |
| | | Nitrogen Dioxide | 3 | ppm | 0 | ppm H2S |
| Sulfur Dioxide | 2 | ppm | 0 | ppm H2S | | |
| O2 | OPT-R1S-OX1 | Carbon Dioxide | 1 | %vol | Enhance O2 reading by 0.3 | %vol O2 |
| | | Hydrogen | 100 | %vol | -9 | %vol O2 |
| | | Methane | 100 | %vol | No response | %vol O2 |
| | | Nitrogen Dioxide | 25 | %vol | No response | %vol O2 |
| SO2 (Low range) | OPT-R1S-SO1 | Carbon Monoxide | 300 | ppm | <3 | ppm SO2 |
| | | Hydrogen Sulfide | 15 | ppm | 0 | ppm SO2 |
| | | Nitrogen Monoxide | 35 | ppm | 0 | ppm SO2 |
| | | Nitrogen Dioxide | 5 | ppm | ~-5 | ppm SO2 |

2.3.3 Sensors Warm Up Time



CAUTION

RISK OF MALFUNCTION

- Before initial calibration, allow the sensor to stabilize for 30 minutes after applying power. In the Zero and Span Calibration modes, the current output from the sensor is inhibited (default 2mA) to avoid false alarms.

| Sensor | OmniPoint Max. warm up time (secs) |
|-------------------------------|------------------------------------|
| NH ₃ | 180 |
| NH ₃ (high) | 180 |
| CO | 60 |
| Cl ₂ | 60 |
| H ₂ S | 60 |
| H ₂ S (high) | 60 |
| O ₂ | 1800 |
| SO ₂ | 60 |
| FL-CAT | 60 |
| CH ₄ -IR | 60 |
| C ₃ H ₈ | 60 |

2.3.4 Sensor Module Distances

The maximum resistance in the field cable is calculated as follows:

$$R \text{ loop} = (V \text{ controller} - V \text{ drop max} - V \text{ detector min}) / I \text{ detector}$$

Example 1 – *Configuration of OmniPoint with EC sensors (detector):*

The controller is supplying a minimal 12 Vdc (V controller), the maximum internal drop voltage between the Transmitter and Sensor module is 2.92 Vdc (V drop max), the detector minimum allowable voltage is 9 Vdc (V detector min), the maximum permissible voltage drop between the controller and detector is 0.08Vdc; this means a voltage drop of 0.04 Vdc in each core.

The detector consumes 0.3 Watts of power. The current required to drive the detector at the minimum voltage is $(I = P / V)$, $0.3 / 9 = 34 \text{ mA}$ (I detector).

So, the maximum field cable loop resistance (R loop) = $0.08 / 0.034 = 2.3 \Omega$, or 1.15Ω per core (allowing for component variations, losses, etc.).

The following chart shows the maximum cable distances between the Transmitter and Sensor module for a 0.25 mm² (24 AWG*) to 1.5 mm² (16 AWG*) core cable. The tables are examples only, and the application's actual cable parameters and source power supply voltage should be used to calculate the maximum cable distance allowed at the installation site.

Example2 – *Configuration of OmniPoint with catalytic sensors (detector):*

The controller supplies a nominal 24 Vdc (V controller). The maximum internal drop voltage between the Transmitter and Sensor module is 2.92 Vdc (V drop max). The detector's minimum allowable voltage is 9 Vdc (V detector min). The maximum permissible voltage drop between the controller and detector is 12.08 Vdc; this means a voltage drop of 6.04 Vdc in each core.

The power consumption of the detector is 1.7 Watts. The current required to drive the detector at the minimum voltage is $(I = P / V)$, $1.7 / 9 = 189 \text{ mA}$ (I detector).

So, the maximum field cable loop resistance (R loop) = $12.08 / 0.189 = 62 \Omega$, or 31Ω per core (allowing for component variations, losses, etc.).

However, The maximum allowable R loop of the Sensor module is 44Ω or 22Ω per core.

The following chart shows the maximum cable distances between the Transmitter and Sensor module for a 0.25 mm² (24 AWG*) to 1.5 mm² (16 AWG*) core cable. The tables are examples only, and the application's actual cable parameters and source power supply voltage should be used to calculate the maximum cable distance allowed at the installation site.

| | | Sensor Module Distances: 12 Vdc supply | | Sensor Module Distances: 24 Vdc supply | |
|-----|--------------------------------------|---|--|---|--|
| AWG | Metric Wire Gauge (mm ²) | EC Sensors (distance in meters) | FL and IR Sensors (distance in meters) | EC Sensors (distance in meters) | FL and IR Sensors (distance in meters) |
| 24 | 0.25 | 13 (42 ft.) | 2 (6 ft.) | 260 (853 ft.) | 260 (853 ft.) |
| 22 | | 21 (68 ft.) | 4 (13 ft.) | 300 (984 ft.) | 300 (984 ft.) |
| 20 | 0.5 | 34 (111 ft.) | 6 (19 ft.) | 300 (984 ft.) | 300 (984 ft.) |
| 18 | | 54 (177 ft.) | 10 (32 ft.) | 300 (984 ft.) | 300 (984 ft.) |
| 16 | 1.5 | 87 (285 ft.) | 16 (52 ft.) | 300 (984 ft.) | 300 (984 ft.) |

- The maximum allowable distance is 300 m (984 ft.)
- The maximum allowable R loop is 44 Ω or 22 Ω per core

*nearest equivalent

NOTE: Sufficient operational margins should be allowed.

OmniPoint sensor module Wiring Recommendations

When wiring the OmniPoint transmitter and OmniPoint sensor module for remote applications, the general recommendations of the ANSI/TIA/EIA-485-A standard must be adhered to with the following additions:

- When mounting the OmniPoint sensor module, run wiring connections between each Sensor module and the transmitter in a dedicated separate conduit.
- Honeywell recommends that the OmniPoint sensor module and the OmniPoint transmitter be wired to the building ground. The system should be grounded at one point only.

OmniPoint sensor module Cable length

Individually shielded twisted pair cable is the recommended wiring practice, in single-pair or multi-pair varieties. Unshielded cables may be used for short distances if ambient noise and cross-talk will not affect communication.

In most installations, the theoretical limit for remote sensor module communication is 300m or more.

However, the cable's electrical characteristics (mostly capacitance) and the combination of connected devices can affect the maximum allowable cable length of the remote sensor module.

So, sufficient operational margins should be allowed.

3 INSTALLATION

3.1 Mounting the Transmitter

The transmitter can be attached to flat wall surfaces of various types or pipes using the optional Pipe Mount Kit.

Wall



Vertical pipe



Horizontal pipe



The pipe mount kit allows the transmitter to be mounted to pipes from 2" –6" (50-140mm) in diameter. It includes the pipe mount bracket, carriage bolts, nuts, and lock washers.

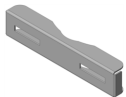

Pipe Mount Bracket



Short Bolt
Carriage Bolt 5/16"-18, L4.25",
SUS
Mcmaster 92356A312



Long Bolt
Carriage Bolt 5/16"-18, L7", Zinc-Plated Steel
Mcmaster 90185A231



Washer
Flat washer 5/16" screw size,
SUS
Mcmaster 92141A030



Nut
Hex nut 5/16"-18, SUS
Mcmaster 92673A119



Split lock washer 5/16", SUS McMaster
92146A030

The transmitter is configured with five cable/conduit ports built into the housing for wiring and mounting sensors. For relay wiring, please refer to the User Manual.

Drill 4X holes corresponding to the appropriate hardware from the following chart.

| Mounting hardware | | | |
|---------------------------------|--|---|----------------|
| Mounting surface | Example part | Description | Drill bit size |
| Drywall, plaster, wood paneling | McMaster-Carr 97121A043 (Quantity: 4 each) In the case of McMaster-Carr 90107A029 (Quantity: 4 each) | Rounded Head Toggle Bolt <ul style="list-style-type: none"> • Thread 1/4in – 20 • Length 3in • 2-1/8in Wing-Span Toggle • Pull-out Strength: 50lbs/ 316 Stainless Steel Washer <ul style="list-style-type: none"> • For screw 1/4in • ID 0.281in / OD 0.625in / Thickness 0.043in-0.057in | 5/8in |
| Concrete | McMaster-Carr 97083A210 (Quantity: 4 each) And McMaster-Carr 90272A540 (Quantity: 4 each) In case McMaster-Carr 90107A029 (Quantity: 4 each) | Steel Female-Threaded Anchor for Concrete <ul style="list-style-type: none"> • Thread 1/4in – 20 • Length 1in • Pull-out Strength: 495 lbs / • Shear Strength: 530lbs Zinc-Plated Steel Pan Head Phillips Screw <ul style="list-style-type: none"> • Thread 1/4in – 20, Length 3/4in 316 Stainless Steel Washer <ul style="list-style-type: none"> • For screw 1/4in • ID 0.281in / OD 0.625in / Thickness 0.043in-0.057in | 3/8in |

3.2 Wiring the Transmitter



WARNING

RISK OF RADIO FREQUENCY INTERFERENCE

The sensor must be earthed/grounded for intrinsic safety, electrical safety and to limit the effects of radio frequency interference. Earth/ground points are provided inside and outside the unit. EMI note for applications using shielded cable: Cable shield must provide 90% of wiring coverage. Cable shield terminations must be made at the cable glands with suitable EMI-type glands. Avoid terminating cable shields at the Earth ground lug inside the OmniPoint enclosure. In cases where wiring is in a pipe, a shielded cable is not required.

The internal grounding terminal shall be used as the primary equipment ground. The external terminal is only a supplemental bonding connection where authorities permit or require such a connection.

Display Module Overview

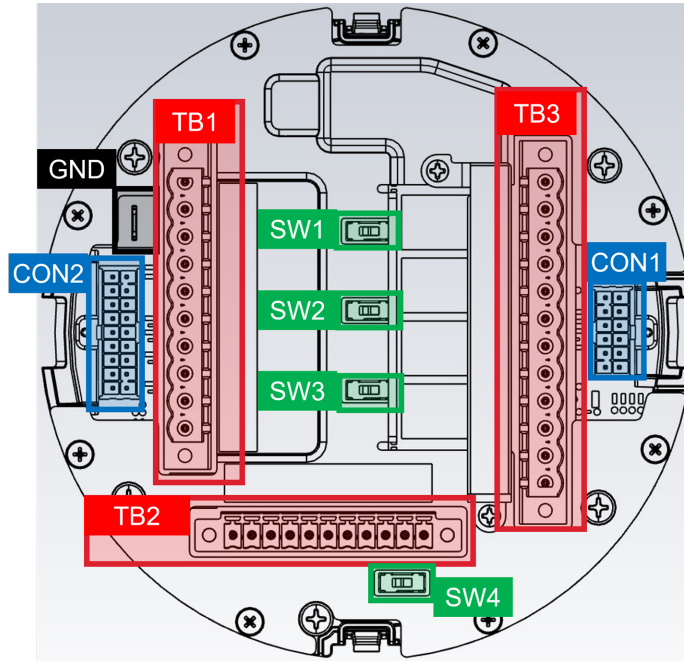

| Description | | How to Connect |
|-------------|--|---|
| TB1 | Power and mA Output | Pluggable terminal block 12 to 28AWG (2.5 to 0.5mm ²) |
| TB2 | Sensor Inputs | Pluggable terminal block 14 to 28AWG (2.0 to 0.5mm ²) |
| TB3 | Relays | Pluggable terminal block 12 to 28AWG (2.5 to 0.5mm ²) |
| CON1 | Optional wireless communications | Customized wiring harness. Provided by Honeywell |
| CON2 | Optional digital communications | Customized wiring harness. Provided by Honeywell |
| SW1 | To configure the isolated mA output of Channel 1 | N/A |
| SW2 | To configure the isolated mA output of Channel 2 | N/A |
| SW3 | To configure the isolated mA output of Channel 3 | N/A |
| SW4 | To configure mA input mode, sink or source | N/A |
| GND | To internal ground lug | Customized wiring harness. Provided by Honeywell |

3.2.1 General Wiring Considerations

For proper operation of the OmniPoint Transmitter and sensor technologies, consideration of wiring-induced voltage drops, transient electrical noise, and dissimilar earth ground potentials is imperative in the design and installation of the system.

EMI NOTE FOR APPLICATIONS USING SHIELDED CABLE: Cable shield must provide 90% wiring coverage. Cable shield terminations must be made at the cable glands with suitable EMI-type glands. Avoid terminating cable shields at the earth-ground lug inside the OmniPoint enclosure.

Loading

When wiring for DC power and a 4–20mA signal, remote wiring to sensors must be sized sufficiently to provide adequate voltages for the line length and the loads used.

Isolation

Isolating power and signal-carrying conductors is recommended.

Circuit Protection

Supply circuits must provide over-current protection. Class 2 power supplies are required for 24 volt DC supplies. Consider inrush current when specifying any DC supply. The power supply range is 12 to 32 VDC for EC, catalytic, and IR versions and 18 to 32 VDC for Searchpoint Optima Plus.

Loads

High inrush or inductive loads may affect the transmitter's performance. For best reliability, use resistive loads only.

Power Source Selection

For each type of installation, the selection of a power supply is essential. Power supplies are rated by voltage and power. The nominal voltage for all Omnipoint transmitters is 24Vdc, with the energy required depending on the number of points using the same power supply.

| Module | Maximum Power Consumption [W] |
|-----------------------------|-------------------------------|
| Transmitter | 8.5 |
| XPIS (EC) sensor | 0.3 |
| XP (catalytic or IR) sensor | 1.7 |
| Optima Plus sensor | 4.5 |

As a general guideline, the power supply should be capable of providing more power than is required by the installation. A 10-watt power supply is fine for a single OmniPoint with Toxic sensor (8.8 watts (8.5 + 0.3) required, see the following table) but is inadequate for a single OmniPoint with SearchPoint Optima Plus (13 watts required).

To determine the wattage required, add the maximum power requirements of all the points that will share the power supply. For example, consider a system with two OmniPoint transmitters with catalytic sensors (8.8 watts each) and one OmniPoint with SearchPoint Optima Plus (13 watts). A 32-watt power supply would probably handle this installation, but a 35-watt one would be better.

Wire Selection

The type of wire used for connections influences the distance of the installation. This is because some voltage is lost in the wire to the transmitter.

Thinner wire (i.e., 18 AWG) will lose more voltage than thicker wire (i.e., 12 AWG). The voltage lost depends on how much power is drawn through the wire; more power means more loss. If too much voltage is lost in the wiring, there may not be enough at the distant point to allow the transmitter to operate.

3.2.2 Transmitter Distances

Use the following chart for installations with dedicated wiring between the transmitter and the power supply. These distances assume the stranded wire is used. If multiple transmitters use the same power supply, ensure the power supply wattage rating is high enough to power all transmitters simultaneously.

The maximum resistance in the field cable is calculated as follows:

$$R \text{ loop} = (V \text{ controller} - V \text{ detector min}) / I \text{ detector}$$

Configuration example: *OmniPoint with two catalytic sensors and Optima Plus.*

The controller supplies a nominal 24 Vdc (V controller), and the detector's minimum allowable voltage is 18 Vdc (V detector min); therefore, the maximum permissible voltage drop between the controller and detector is 6 Vdc. This means a voltage drop of 3 V in each core (V+ core and V–core).

The detector consumes 17.0 Watts of power. The current required to drive the detector at the minimum voltage is ($I = P / V$), $17.0 / 18 = 945 \text{ mA}$ (I detector).

So, the maximum field cable loop resistance ($R \text{ loop}$) = $6 / 0.945 = 6 \Omega$, or 3Ω per core (allowing for component variations, losses, etc.).

The following chart shows the maximum cable distances between the controller and OmniPoint for a 1.0 mm² (18 AWG*) to 3.5 mm² (12 AWG*) core cable for different termination unit options, assuming a voltage drop of 3 V in each core. The tables are examples only, and the application's actual cable parameters and source power supply voltage should be used to calculate the maximum cable distance allowed at the installation site.

| Single Transmitter Distances: 24 Vdc supply | | | | |
|--|----------------------------------|----------------------------------|----------------------------------|----------------------------------|
| Configuration | 18 AWG [1.0 mm ²] | 16 AWG [1.5 mm ²] | 14 AWG [2.0 mm ²] | 12 AWG [3.5 mm ²] |
| OmniPoint with XPIS (EC) 2ea and Searchpoint Optima Plus | 557 feet [170 meters] | 918 feet [280 meters] | 1476 feet [450 meters] | 2329 feet [710 meters] |
| OmniPoint with XPIS (EC), XP (Catalytic or IR) and Searchpoint Optima Plus | 524 feet [160 meters] | 853 feet [260 meters] | 1378 feet [420 meters] | 2198 feet [670 meters] |
| OmniPoint with XP (Catalytic or IR) 2ea and Searchpoint Optima Plus | 459 feet [140 meters] | 721 feet [220 meters] | 1181 feet [360 meters] | 1870 feet [570 meters] |

*nearest equivalent

NOTE: Sufficient operational margins should be allowed

Wiring for Power

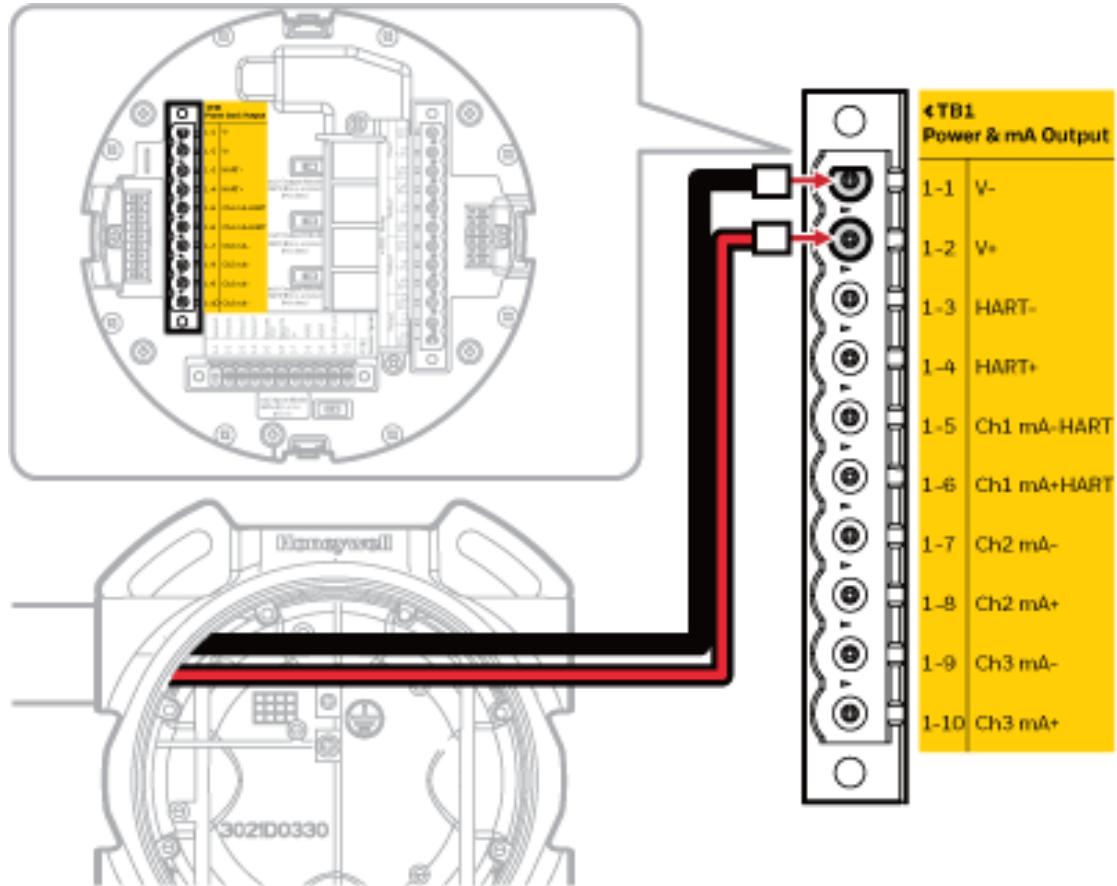

Ensure that sufficient power is supplied; 24 VDC is required. Circuits are limited to overvoltage category III or less. Use wires size 30 - 12 AWG and tightening torque of 5 - 7 Lb-in.

mA Output Mode

The total load resistance for the 4-20mA output should be kept lower than 500Ω, including the resistance of the adequately selected 4-20mA cable and the input impedance of the equipment to be connected. The minimum loop impedance is 200 ohms; the maximum is 500 ohms. If the 20 mA output is not used, a 500 ohm resistor must be installed. The Omnipoint Transmitter power consumption depends on the sensor and options for the specific configuration. The input voltage must be maintained for proper operation, referring to the following Loop R table.

The maximum loop resistance, including the field cable, is calculated as follows:

$$\text{Loop R} = (\text{V detector} - \text{V drop max}) / \text{Max. mA output}$$

Example: The controller supplies a minimal 12 Vdc (V detector), and the maximum internal drop voltage is 7.5 Vdc (V drop max); therefore, the maximum allowable voltage drop of 4-20mA Loop is 4.5 Vdc.

The maximum current required to drive the 4-20mA is 22 mA (Max. mA output).

So, the maximum Loop resistance (Loop R) = 4.5 / 0.022 = 200 Ω (allowing for component variations, losses, etc.).

| Maximum Loop Resistance | |
|-------------------------|-----------------|
| V Detector | Loop Resistance |
| 12 Vdc | 200 Ω |
| 14 Vdc | 290 Ω |
| 16 Vdc | 380 Ω |
| 18 Vdc | 470 Ω |
| 24 Vdc | 500 Ω |
| 32 Vdc | 500 |

The maximum allowable loop resistance is 500 Ω .

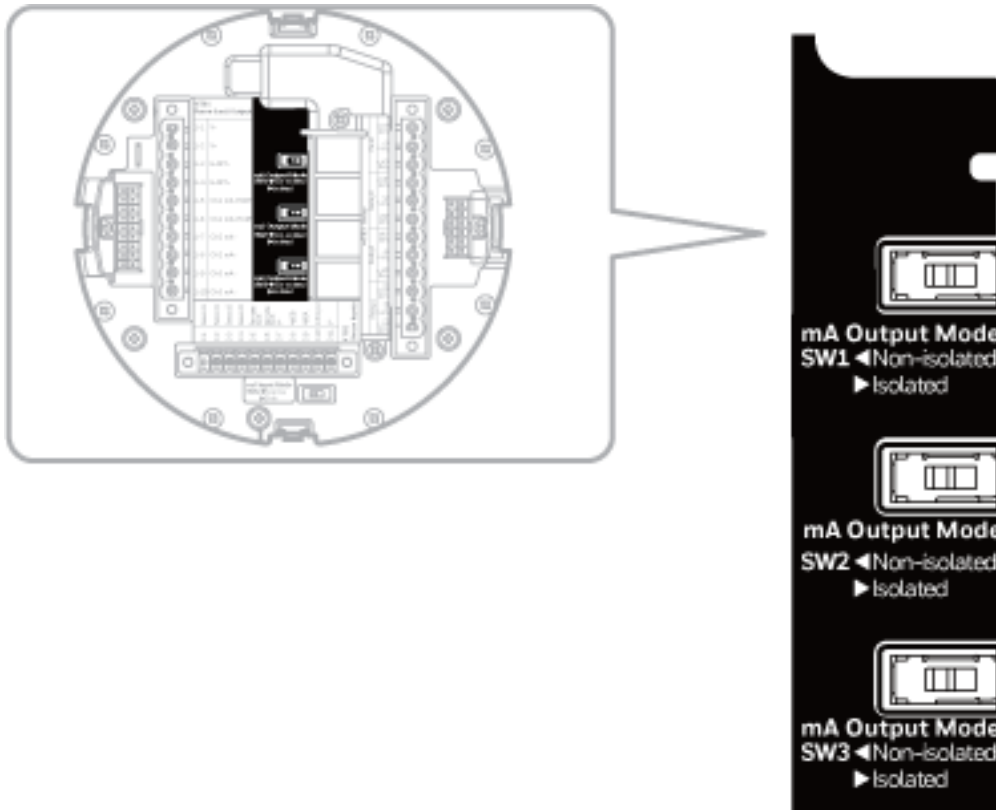

For MODBUS - Use wires size 30 - 12 AWG and tightening torque of 5 - 7 Lb-in.

Sink Wiring:

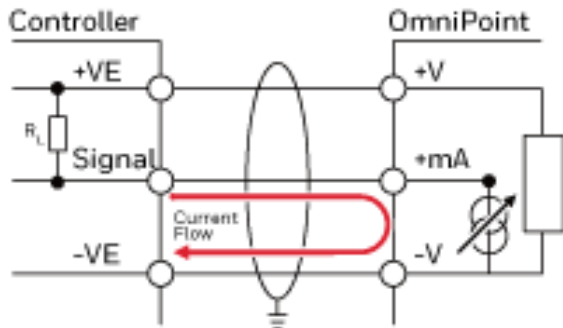

Isolated wiring:

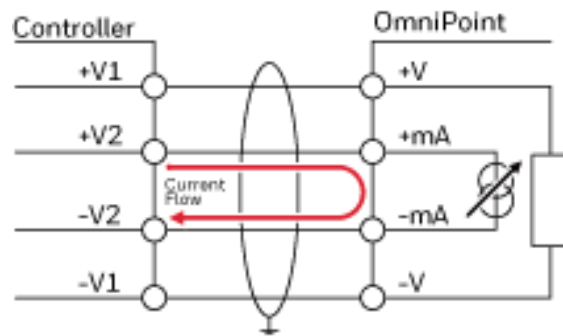

Source wiring:

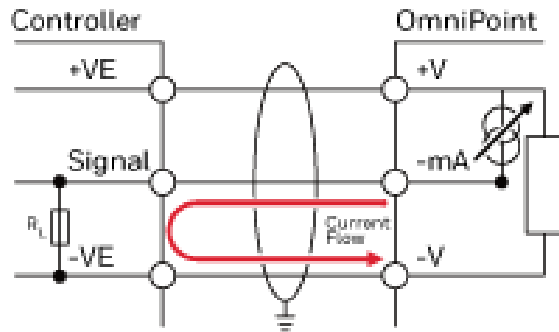

XP and XPIS Sensor to TX Wiring

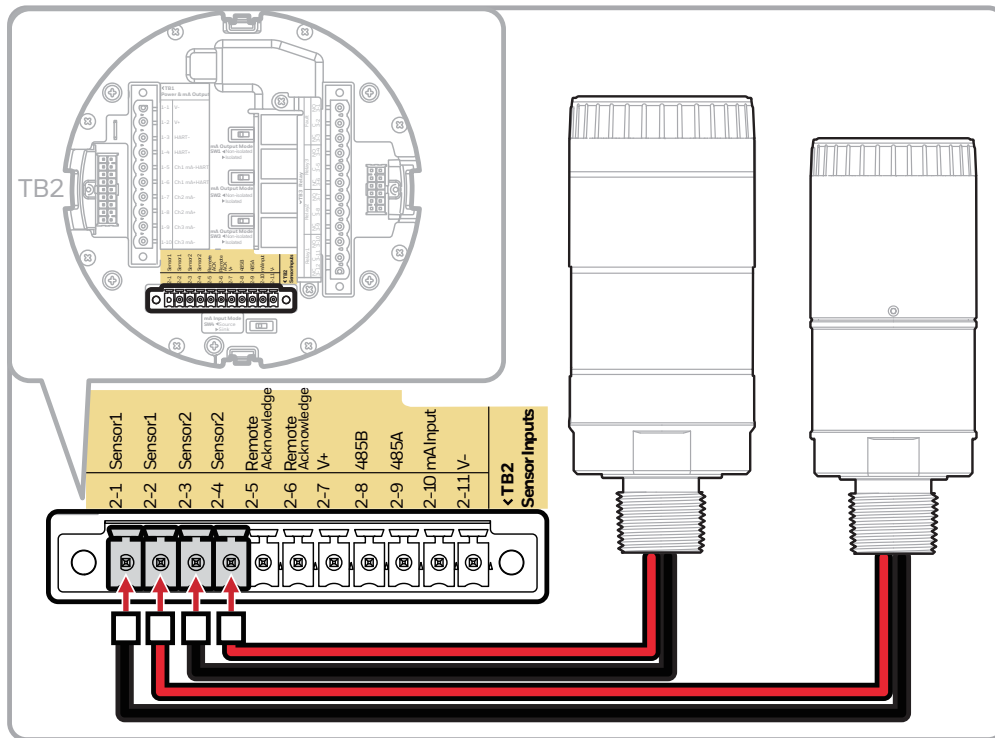

Ensure sensors are installed to the transmitter with a min. 30Nm / MIN 266lbf in. Use wires size 30-14 AWG and tightening torque of 2 - 2.2 Lb-in

Optima to TX Wiring

| Wire Color | Connection | Purpose |
|--------------|----------------|------------------|
| Red | +24 Vdc | +ve Supply |
| Black | 0 Vdc | -ve Supply |
| White | 4-20 mA Output | Signal |
| Orange | RS485 A | Communication |
| Blue | RS485 B | Communication |
| Green/Yellow | Earth | Protective Earth |

Remote Mount Sensor Configuration

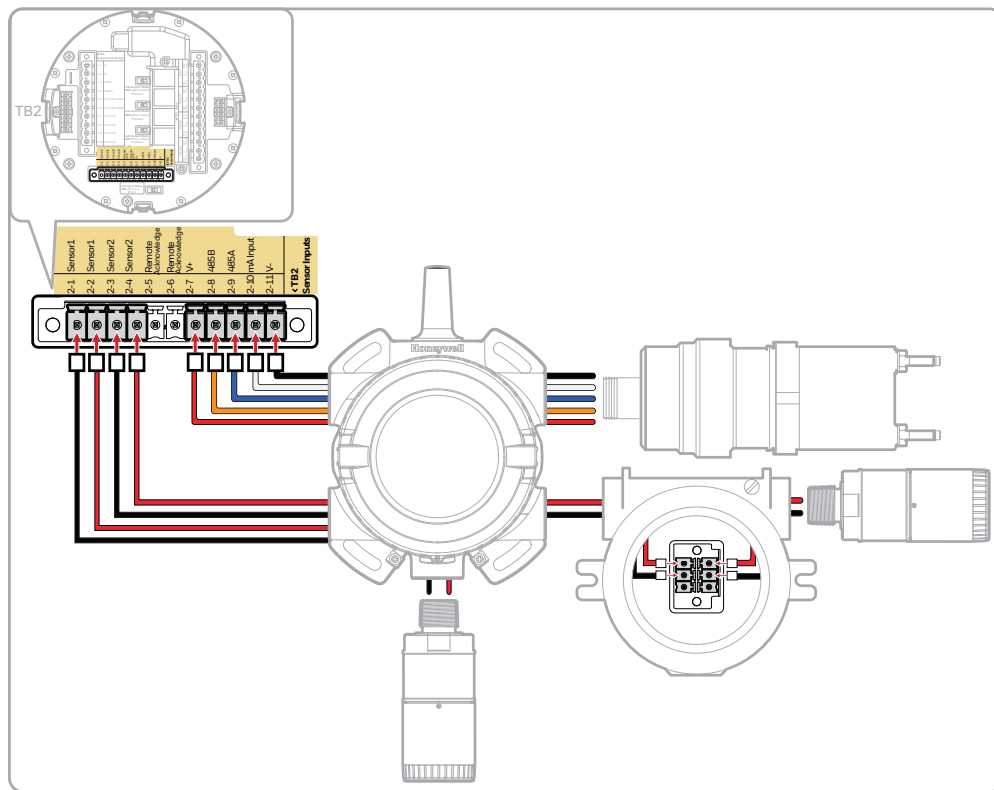

For NPT Threads configuration, ensure a minimum engagement of 5; for Metric Threads configuration, ensure a minimum engagement of 8. Honeywell recommends using Akron Electric INC., Part Nos. 2430-0021 and 2441-0022 Junction Boxes. Ensure use of appropriate junction box per local requirements.

3.2.3 Sensor wiring For Terminal Block 2 (TB2)

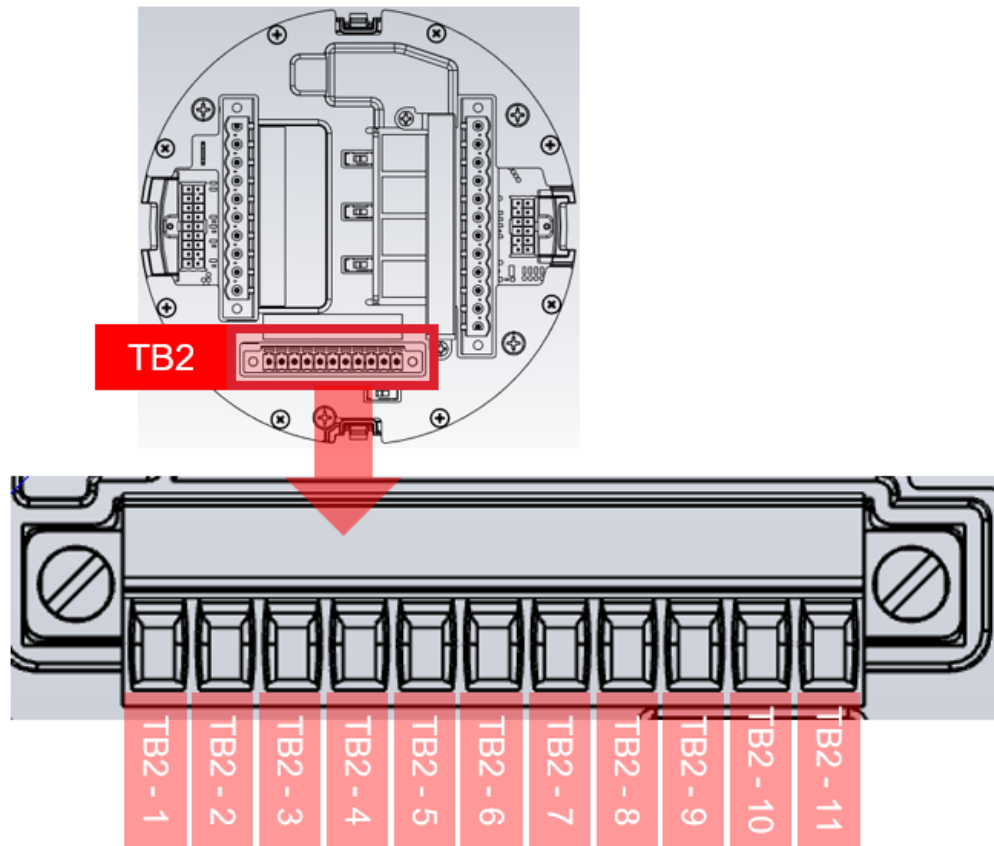

TB2 is for sensor inputs and remote acknowledgement to reset the alarm or fault

| Number | Category | Description |
|----------|------------|---|
| TB2 – 1 | SENSOR 1 | The Input of the new OmniPoint sensor 1 |
| TB2 – 2 | SENSOR 1 | The Input of the new OmniPoint sensor 1 |
| TB2 – 3 | SENSOR 2 | The input of the new OmniPoint sensor 2 |
| TB2 – 4 | SENSOR 2 | The input of the new OmniPoint sensor 2 |
| TB2 – 5 | REMOTE_ACK | Remote ACK input to reset alarm relays |
| TB2 – 6 | REMOTE_ACK | Remote ACK input to reset alarm relays |
| TB2 – 7 | Optima | Supply power V+ (+24Vdc) to Optima |
| TB2 – 8 | Optima | RS485_B with Optima |
| TB2 – 9 | Optima | RS485_A with Optima |
| TB2 – 10 | Optima | mA input from Optima |
| TB2 – 11 | Optima | Supply power V- (0Vdc) to Optima |

3.2.4 Sensor Wiring

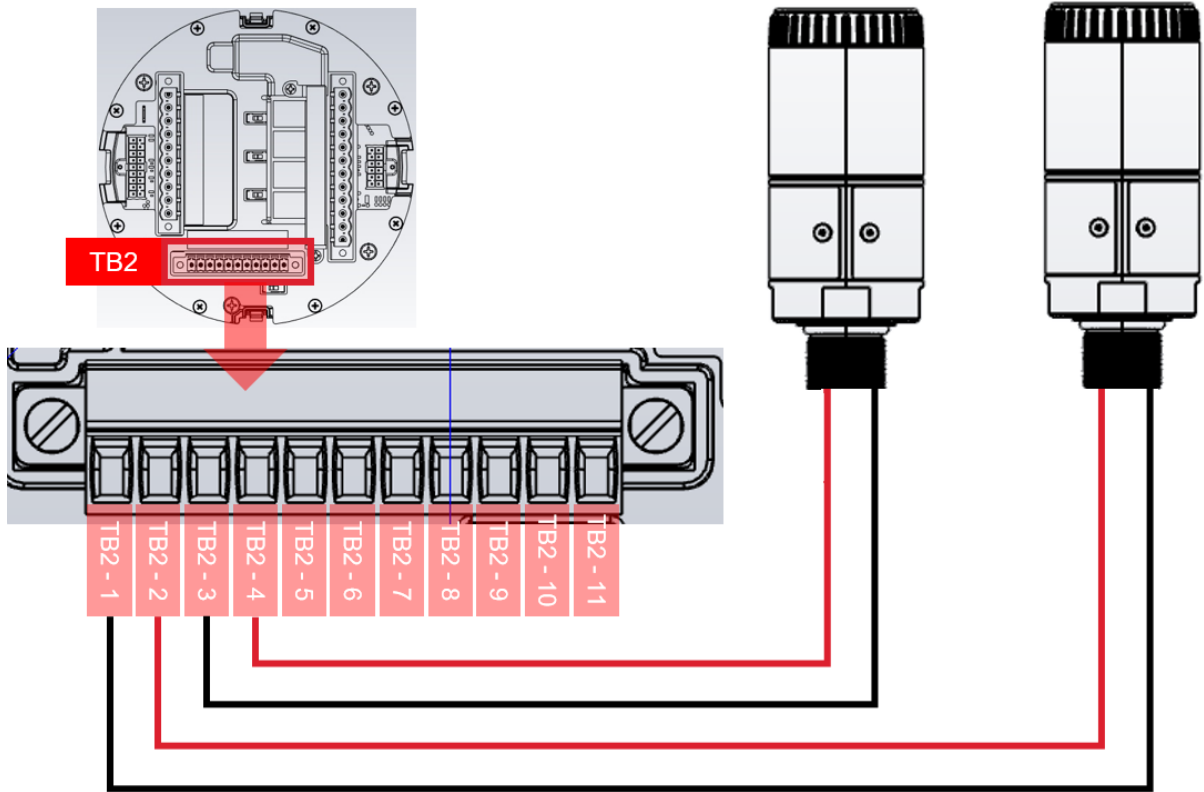

TB2 has connections for two OmniPoint sensor modules

3.2.5 Optima Wiring

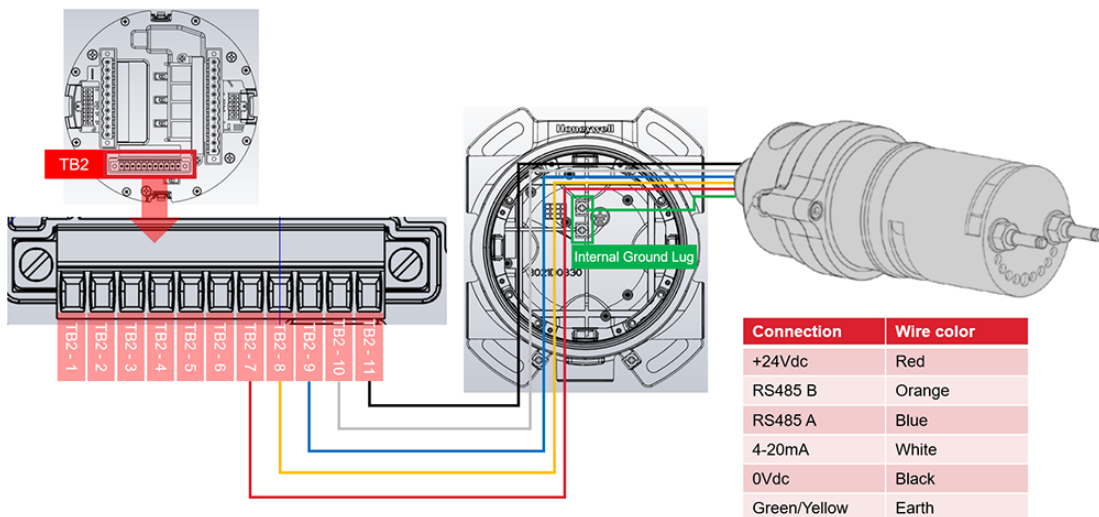

TB2 has connections for Searchpoint Optima

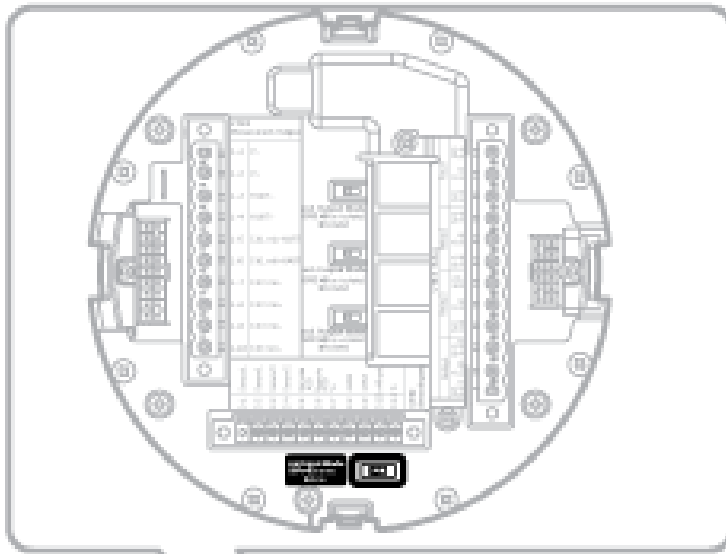

mA Input Mode
SW4 ◀ Source
 ▶ Sink

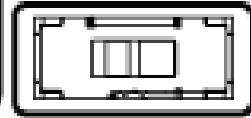

mA input source:

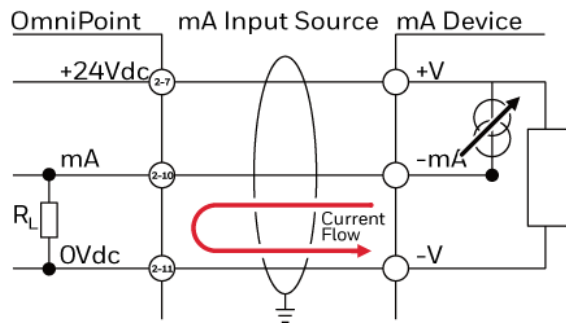

mA input sink:

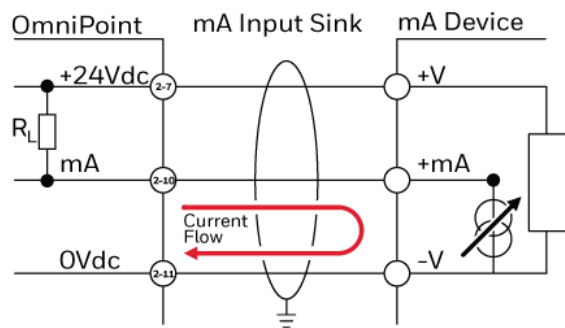

3.2.6 Remote reset connection and remote distance

WARNING

- The user is responsible for ensuring that the Remote switch is guarded against unauthorized access or tampering.

TB2 is provided as a connection to a user-installed momentary switch to reset alarms or faults remotely.

Maximum Rloop resistance for a remote reset switch is 18 Ω, i.e. ≤500 m of 1 mm² shielded cable.

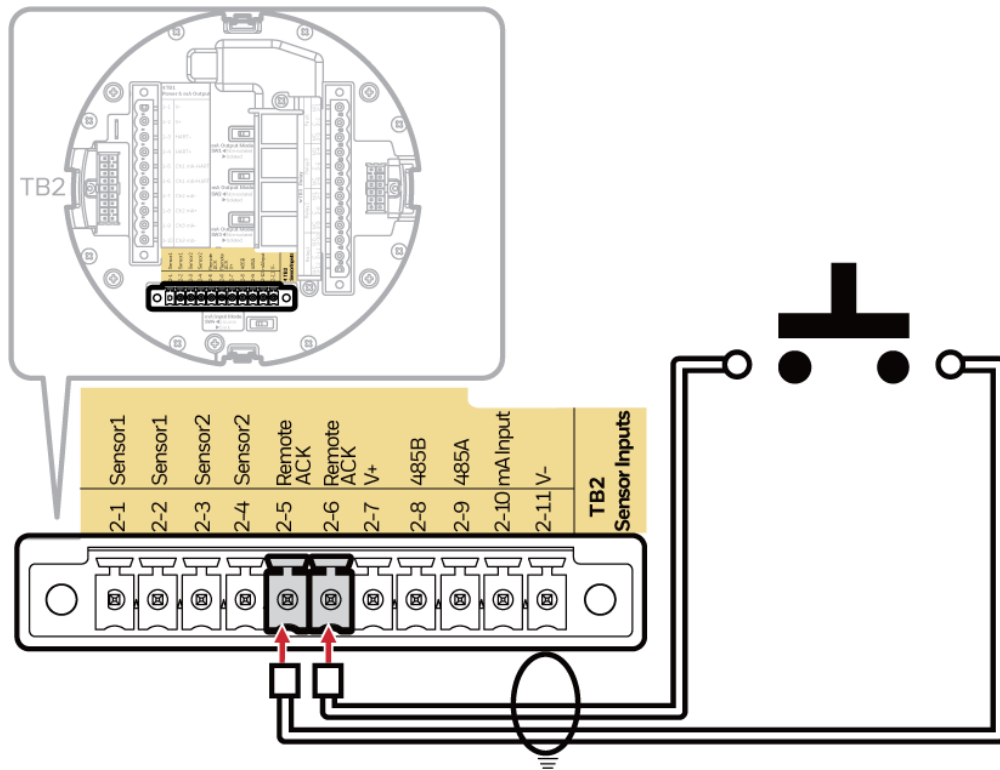

Grounding and EMI

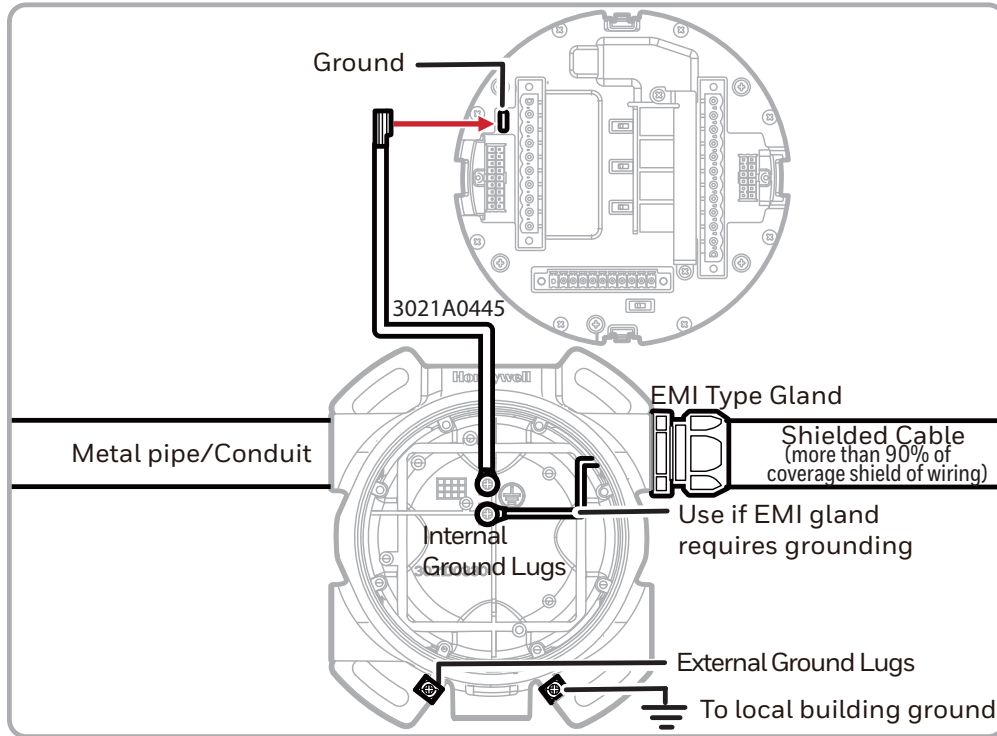

Internal ground connection: Utilize the shield of the wiring cable recommended in the wiring instructions. For connection to this terminal, twist the shield wire to avoid stray shield wires. Loosen the screw sufficiently and wrap the wire around the screw in a "U" shape. Raise the clamp and place the wire between the clamp and ground base, lower the clamp, and tighten the screw for a torque of 6.9 lb-in.

External ground connection: If local authority requires, utilize at least 4mm² copper (stranded or solid) wire. Loosen the screw sufficiently to enable wrapping the wire around the screw in a "U" shape. Raise the clamp and place the wire between the clamp and ground base, lower the clamp, and tighten the screw to a torque of 10.4 lb-in.

Supplemental external bonding terminal should not be used in North American installations unless local authorities permit.

⚠ CAUTION: Any earthing regime employed must avoid earth loops.

The following information is provided to assist with proper earthing of the Omnipoint:

- The Omnipoint provides both internal and external earth ground points. This facilitates connecting the detector to the protective earth.
- The internal earth shall be used for the equipment grounding connection. It must be at least equal in mm² to the incoming power conductors.
- The EXTERNAL earth provides a supplementary bonding connection, which allows for the connection of field wiring conductors of at least 4mm².

3.3 Relays

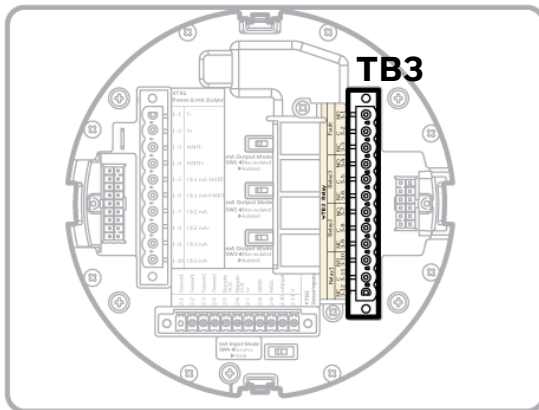

Use wires size 30 - 12 AWG and tightening torque of 5 - 7 Lb-in.

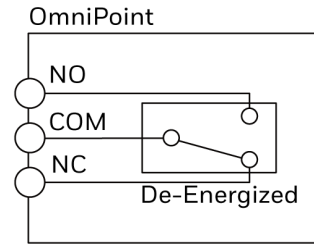
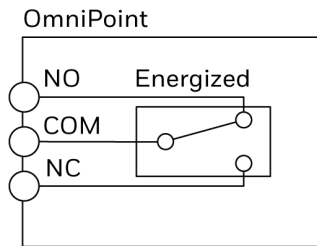
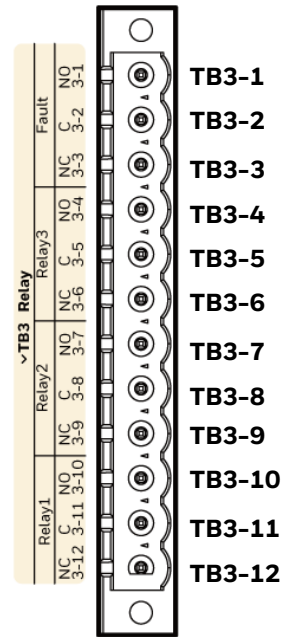

| Number | Category | Description |
|----------|---------------|-------------------------------------|
| TB3 - 1 | Fault Relay | NO (Normal Opened) of fault relay |
| TB3 - 2 | Fault Relay | COM of fault relay |
| TB3 - 3 | Fault Relay | NC (Normal Closed) of fault relay |
| TB3 - 4 | Alarm Relay 3 | NO (Normal Opened) of alarm relay 3 |
| TB3 - 5 | Alarm Relay 3 | COM of alarm relay 3 |
| TB3 - 6 | Alarm Relay 3 | NC (Normal Closed) of alarm relay 3 |
| TB3 - 7 | Alarm Relay 2 | NO (Normal Opened) of alarm relay 2 |
| TB3 - 8 | Alarm Relay 2 | COM of alarm relay 2 |
| TB3 - 9 | Alarm Relay 2 | NC (Normal Closed) of alarm relay 2 |
| TB3 - 10 | Alarm Relay 1 | NO (Normal Opened) of alarm relay 1 |
| TB3 - 11 | Alarm Relay 1 | COM of alarm relay 1 |
| TB3 - 12 | Alarm Relay 1 | NC (Normal Closed) of alarm relay 1 |

Relay rating: 250 VAC 5A, 24VDC 5A Resistive Loads Only.

3.3.1 Relay Settings

There are three alarm relays and one fault relay.

Alarm relays can be set independently:

- **Link:** It is an item that sets which sensors or alarms to link the relay to. The following 6 options are provided
 - Alarm 1 for any sensor
 - Alarm 2 for any sensor
 - Any alarm for sensor 1
 - Any alarm for sensor 2
 - Any alarm for sensor 3
 - Disabled
- **Normal State:** It is a setting item for a relay's state when it is not operational (a normal situation).
 - (normally) Energized: normally open (NO)
 - (normally) De-energized: normally closed (NC)
- **Ack (acknowledge) option** Relay acknowledge enable/disable option. If enabled, the relay can be acknowledged(released) when requesting relay ack.

The fault relay cannot be configured and operates in a normally energized (NC).

To set the relays:

1. Tap **Setting** menu.
2. Select **Relays**.
3. Select the Relay to set, and follow the onscreen instructions.

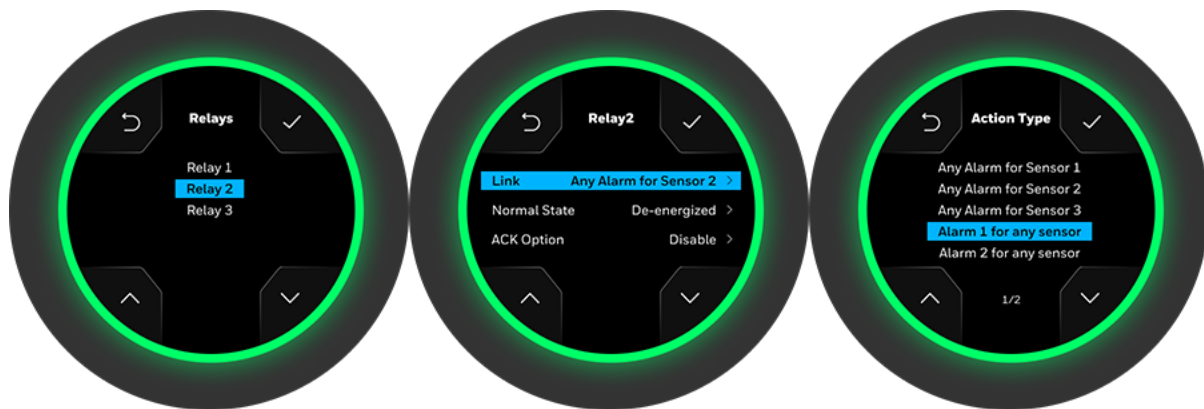

3.4 4-20mA Output, Common Connections, and Power Settings

The total load resistance for the 4-20mA output should be kept lower than 500Ω, including the resistance of the adequately selected 4-20mA cable and the input impedance of the equipment to be connected. The minimum loop impedance is 200 ohms; the maximum is 500 ohms. If the 20 mA output is not used, a 500 ohm resistor must be installed. The Omnipoint Transmitter power consumption depends on the sensor and options for the specific configuration. The input voltage must be maintained for proper operation, referring to the following Loop R table.

The maximum loop resistance, including the field cable, is calculated as follows:

$$\text{Loop R} = (\text{V detector} - \text{V drop max}) / \text{Max. mA output}$$

Example: The controller supplies a minimal 12 Vdc (V detector), and the maximum internal drop voltage is 7.5 Vdc(V drop max); therefore, the maximum allowable voltage drop of 4-20mA Loop is 4.5 Vdc.

The maximum current required to drive the 4-20mA is 22 mA (Max. mA output).

So, the maximum Loop resistance (Loop R) = 4.5 / 0.022 = 200 Ω (allowing for component variations, losses, etc.).

| Maximum Loop Resistance | |
|-------------------------|-----------------|
| V Detector | Loop Resistance |
| 12 Vdc | 200 Ω |
| 14 Vdc | 290 Ω |
| 16 Vdc | 380 Ω |
| 18 Vdc | 470 Ω |
| 24 Vdc | 500 Ω |
| 32 Vdc | 500 |

The maximum allowable loop resistance is 500 Ω.

4.1 User interface overview

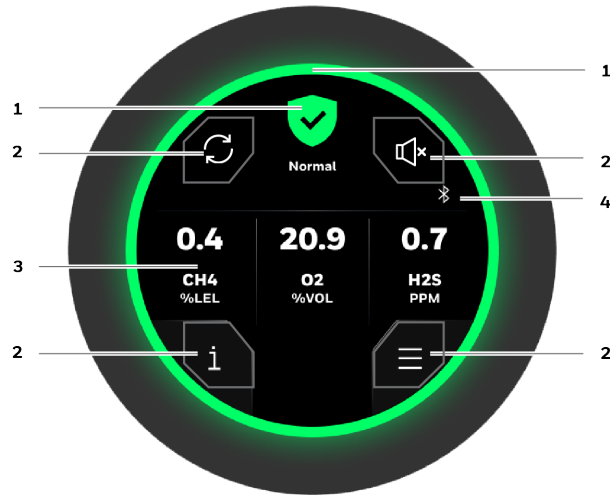



| Number | Description | | | | | | | | | | | | | | | | | | | | |
|--------|---|-----|-------------------|----|-------------------|---|-------------|-----|------------|-----|-----------|-----|--|---|--------|---|-------|---|-------------------------|---|----------------|
| 1 | The LED light ring and Badge show the transmitter's running state | | | | | | | | | | | | | | | | | | | | |
| 2 | <p>Touch keys:</p> <table border="1"> <tr> <td>☰</td> <td>Menu</td> <td>−+</td> <td>Increase/Decrease</td> </tr> <tr> <td>i</td> <td>Information</td> <td>^ v</td> <td>Navigation</td> </tr> <tr> <td>× ✓</td> <td>Selection</td> <td>< ></td> <td></td> </tr> <tr> <td>↶</td> <td>Return</td> <td>↺</td> <td>Reset</td> </tr> <tr> <td>🔊</td> <td>Alarm Relay Acknowledge</td> <td>☑</td> <td>Alarm Snapshot</td> </tr> </table> | ☰ | Menu | −+ | Increase/Decrease | i | Information | ^ v | Navigation | × ✓ | Selection | < > | | ↶ | Return | ↺ | Reset | 🔊 | Alarm Relay Acknowledge | ☑ | Alarm Snapshot |
| ☰ | Menu | −+ | Increase/Decrease | | | | | | | | | | | | | | | | | | |
| i | Information | ^ v | Navigation | | | | | | | | | | | | | | | | | | |
| × ✓ | Selection | < > | | | | | | | | | | | | | | | | | | | |
| ↶ | Return | ↺ | Reset | | | | | | | | | | | | | | | | | | |
| 🔊 | Alarm Relay Acknowledge | ☑ | Alarm Snapshot | | | | | | | | | | | | | | | | | | |
| 3 | Gas readings with gas type and measuring unit. | | | | | | | | | | | | | | | | | | | | |
| 4 | <p>Indication Icons such as:</p> <ul style="list-style-type: none"> • Option module (BLE, MODBUS RTU) installation state • Channel information (order) • Sensor changing indicator • Bump/calibration overdue indicator | | | | | | | | | | | | | | | | | | | | |

4.1.1 Light Ring

| STATUS | Red | Green | Yellow | Blue |
|----------------------|----------------------------------|-------------------------------------|----------|-------|
| Inhibit | | Flashing alternately green & yellow | | |
| Alarm 2 | Flashing | | | |
| Alarm 1 | Solid | | | |
| Fault | | | Flashing | |
| Warning | | | Solid | |
| Warm-up | | Flashing alternately green & yellow | | |
| Normal | | Solid (default) | | |
| Bluetooth connected | | | | Solid |
| Transmitter Updating | Flashing alternately red & green | | | |

4.1.2 Main Menu options

Tap  and select any of the following options:

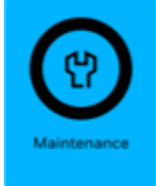
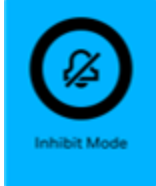
| TEST & Calibration | Settings | Maintenance | Inhibit Mode |
|---|---|--|---|
|  |  |  |  |

- Bump Test
- Calibration
- Test

- General
- Channel
- Sensor
- Inhibit & Fault
- Relays
- Communications
- Security

- Sensor Replacing Guide
- Replace Sensor
- Accept Sensor
- Soft Reset (Optima)
- Calibrate Current Loop
- Factory Reset

4.2 Initial Setup

1. Turn on the OmniPoint. The Light Ring sequence goes green, red, yellow, and blue.
2. The Self-test procedure starts. The Normal screen is displayed after the self-test.
3. *First time Start up only:* Enter a passcode and confirm it. The Normal screen is displayed after typing the passcode.

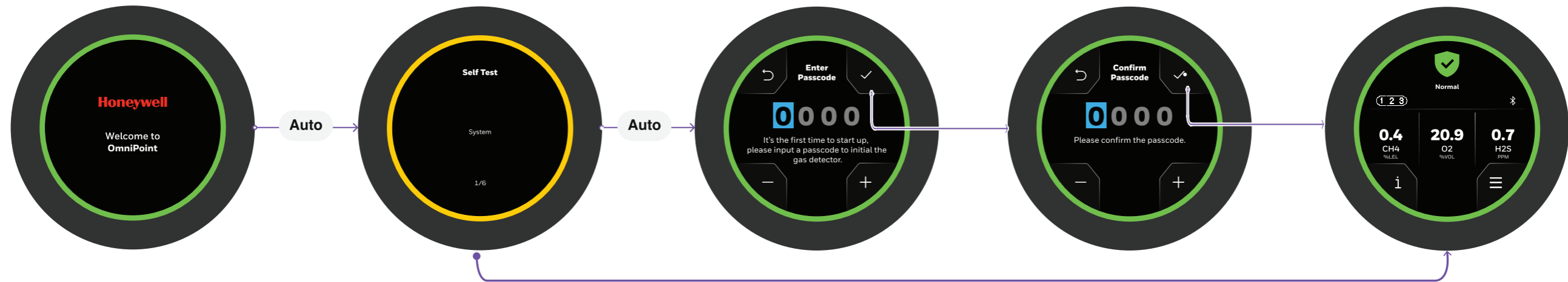

4.3 Calibration

4.3.1 Zero Calibration

1. Tap **Test & Calibration** menu, tap ✓



2. Select **Calibration** and tap ✓



3. Select a channel or sensor to calibrate. Click ✓ to start the Zero calibration.



4. Apply Gas:
 - a. Connect the OmniPoint calibration cap (PN: OPT-CAP) to the regulated cylinder containing a known target gas concentration.
Note: Pay attention to the flow direction and use the recommended flow rate for each

sensor cartridge.

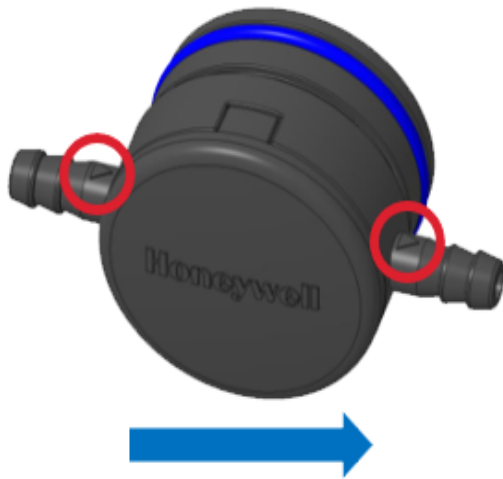

- b. Apply the gas and wait for a few minutes until the reading is stable.
- c. Tap ✓ when the reading is stable.



5. After successful zero calibration, choose whether to proceed with span calibration ✓ or to Skip span calibration X



4.3.2 Span Calibration

1. Set the span calibration point, then tap ✓



2. Apply Gas:

- a. Connect the OmniPoint calibration cap (PN: OPT-CAP) to the regulated cylinder containing a known target gas concentration.

Note: Pay attention to the flow direction and use the recommended flow rate for each sensor cartridge.

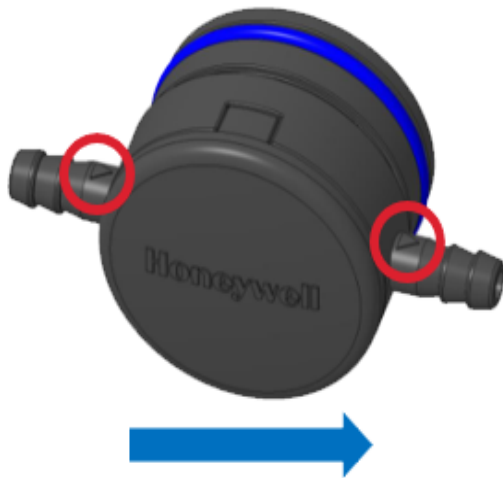

- b. Apply the gas and wait for a few minutes until the reading is stable.
- c. Tap ✓ when the reading is stable.



3. Apply fresh air and tap ✓

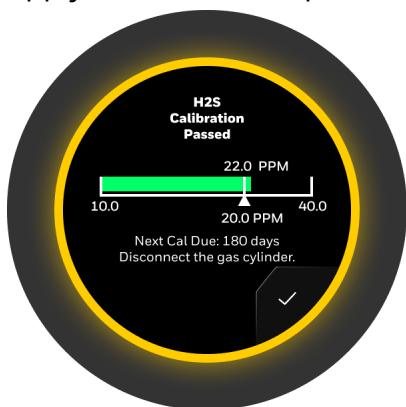

4. Wait until the reading is below the Alarm1. Tap ✓ to exit.



5. Choose whether to continue the calibration of another channel ✓ or exit the calibration ✕



4.3.3 Zero and Span Calibration for XP/XPIS Sensors

CAUTION: Before initial calibration, allow the sensor to stabilize for 30 minutes after applying power.

When in zero and span calibration modes, the current output from the sensor is inhibited (default 2mA) to avoid false alarms.

For sticky gases (Cl₂ and NH₃), use PTFE tubing with short pieces of Tygon tube for the final connection (due to the inflexibility of PTFE). This minimizes the adhesion of the gas to the tube surface and allows more accurate measurement. Use a one-inch section of Tygon tubing as a union sleeve to join the calibration caps' fitting and the PTFE tubing. Push the PTFE tubing against the fitting so they make secure contact as shown in the illustration. Gas should not be able to contact the Tygon sleeve. Attach the PTFE tubing to the regulator in the same manner.

To calibrate the sensor, use an appropriate span gas cylinder, tubing, and calibration cap or gas flow housing. Set the flow regulator (ZCALREG1) to 300- 375 ml/min for XPIS sensors or 300-700 ml/min for XP sensors (Flow regulator PN: N600 1001 33).

If the sensor is located in an area containing any residual amount of the target gas, use a compressed gas cylinder (20.9%Vol oxygen) to perform the zero calibration. If no residual gas is present, background air can perform the zero calibration. Contact a Honeywell representative for details about suitable calibration kits. To calibrate the sensor, follow the steps in the Calibration Procedure.

4.3.4 Cross Calibration for XP Combustible Gas Sensor

CAUTION: When a user calibrates a sensor using a different gas, the user is responsible for identifying and recording the calibration. Refer to local regulations where appropriate.

When the XP Combustible LEL sensor is to be calibrated with a gas which is different from the gas or vapor to be detected, follow this cross-calibration procedure:

These star rating tables list the gases according to the reaction they produce at a given detector.

| Gas | Star Rating |
|------------------|-------------|
| Acetone | 4 |
| Ammonia | 7 |
| Benzene | 3 |
| Butanone | 3 |
| Butane | 4 |
| Butyl acetate | 1 |
| Butyl acrylate | 1 |
| Cyclohexane | 3 |
| Cyclohexanone | 1 |
| Diethyl ether | 4 |
| Ethane | 6 |
| Ethanol | 5 |
| Ethyl acetate | 3 |
| Ethylene | 5 |
| Heptane | 3 |
| Hexane | 3 |
| Hydrogen | 6 |
| Methane | 6 |
| Methanol | 5 |
| MIBK | 3 |
| Nonane | 2 |
| Octane | 3 |
| Pentane | 4 |
| Propane | 5 |
| Propan-2-ol | 4 |
| Styrene | 2 |
| Tetra hydrofuran | 4 |
| Toluene | 3 |
| Triethylamine | 3 |
| Xylene | 2 |

An eight-star (8*) gas produces the highest output, while a one-star (1*) gas produces the lowest. (These are not applicable at ppm levels.)

To cross-calibrate the XP combustible gas sensor:

1. Obtain the star rating for the test gas and the gas to be detected from the Gas Star Ratings table.
2. Set the gas selection to the star rating, the same star rating of the gas detected.

3. These values may then be used in the following table to obtain the required meter setting when a 50% LEL test gas is applied to the detector.

| Test Gas Meter Settings ¹ | | | | | | | | |
|--------------------------------------|-----------------------------------|----|----|----|----|----|----|----|
| Star rating of calibration gas | Star rating of gas to be detected | | | | | | | |
| | 8 | 7 | 6 | 5 | 4 | 3 | 2 | 1 |
| 8 | 50 | 62 | 76 | 95 | | | | |
| 7 | 40 | 50 | 61 | 76 | 95 | | | |
| 6 | 33 | 41 | 50 | 62 | 78 | 95 | | |
| 5 | 26 | 33 | 40 | 50 | 63 | 79 | 95 | |
| 4 | | 26 | 32 | 40 | 50 | 63 | 80 | 95 |
| 3 | | | 26 | 32 | 40 | 50 | 64 | 81 |
| 2 | | | | 25 | 31 | 39 | 50 | 64 |
| 1 | | | | | 25 | 31 | 39 | 50 |

¹ Use these settings only with 50% LEL calibration gas concentration.

4. If a sensor is to be used to detect a gas other than that for which it was calibrated, the required correction factor can be obtained from the following multiplier factors table. Multiply the meter reading by this number to get the true gas concentration.

| Multiple factors | | | | | | | | |
|-----------------------------|--------------------|------|------|------|------|------|------|------|
| Sensor calibrated to detect | Sensors to be used | | | | | | | |
| | 8 | 7 | 6 | 5 | 4 | 3 | 2 | 1 |
| 8 | 1.00 | 1.24 | 1.52 | 1.89 | 2.37 | 2.98 | 3.78 | 4.83 |
| 7 | 0.81 | 1.00 | 1.23 | 1.53 | 1.92 | 2.40 | 3.05 | 3.90 |
| 6 | 0.66 | 0.81 | 1.00 | 1.24 | 1.56 | 1.96 | 2.49 | 3.17 |
| 5 | 0.53 | 0.66 | 0.80 | 1.00 | 1.25 | 1.58 | 2.00 | 2.55 |
| 4 | 0.42 | 0.52 | 0.64 | 0.80 | 1.00 | 1.26 | 1.60 | 2.03 |
| 3 | 0.34 | 0.42 | 0.51 | 0.64 | 0.80 | 1.00 | 1.27 | 1.62 |
| 2 | 0.26 | 0.33 | 0.40 | 0.50 | 0.63 | 0.79 | 1.00 | 1.28 |
| 1 | 0.21 | 0.26 | 0.32 | 0.39 | 0.49 | 0.62 | 0.78 | 1.00 |

Since combustible sensors require oxygen for correct operation, use a gas mixture in the air for calibration. Assuming average sensor performance, the sensitivity information in these tables is normally accurate to $\pm 20\%$.

CAUTION: When calibrating a sensor, the reaction time should be checked by measuring the time from applying test gas to the sensor head to achieve a stable reading. Stability should be achieved within one minute. If this reaction time becomes unduly prolonged, the sensor should be replaced.

Example. If the target gas to be detected is butane and the calibration gas available is methane (50% LEL):

1. Look up the star rating for each gas in the first table: Butane 4* and Methane 6*.
2. Check the meter settings for 50% LEL calibration gas in the second table: 78.
3. Set the meter to 78% to accurately read butane using 50% LEL with methane as the calibration gas.

4.4 Bump Test

1. Select **Test & Calibration** from the main menu.
2. Tap ✓
3. Select **Bump Test**.
4. Tap ✓
5. Select a channel or sensor to bump.
6. Tap ✓ The bump test will start:
 - a. Apply the test gas and check the reading.
 - b. Apply fresh air to finish the bump test and wait until the reading is below the Alarm1
7. Click ✓ to exit.
8. Confirm to exit.

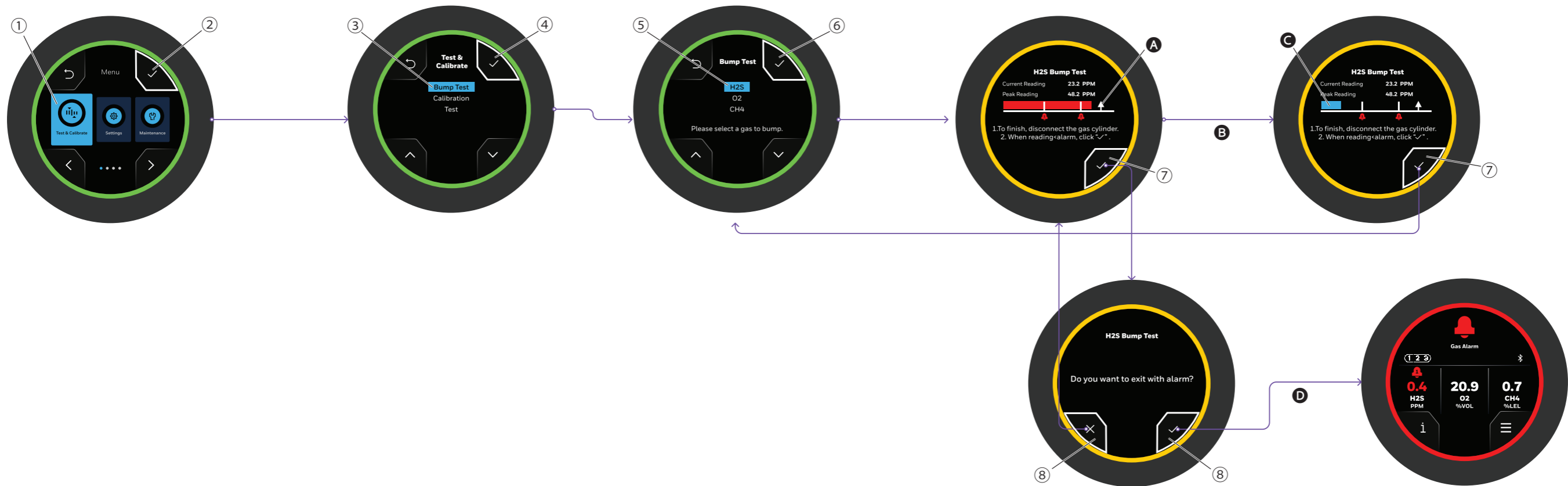

Notes:

- A. The white arrow icon means peak reading and the position is according to the percentage of the full scale.
- B. Assume the gas cylinder is disconnected, and the gas reading goes down
- C. When the reading is beyond Alarm1, the bar turns red, and if the reading is lower than the alarm, the bar turns blue.
- D. Go to the home page.

4.5 Reset Alarm



4.6 Settings

4.6.1 General

| Item | Description | Default |
|-------------|--|---|
| Language | English, French, Spanish, Portuguese, German, Dutch | |
| Date & Time | Available formats: MM/DD/YY, DD/MM/YY, YY/MM/DD Available formats: 24-hour (hh: mm), 12 hour (hh: mm am/pm) Do not support daylight saving | MM/DD/YY 24-hour (hh: mm) |
| Display | Brightness Screen Timeout: 1 to 3600 seconds (1 hour), always on Heart Indicator (transmitter ring-indicator operation on normal state): Solid Green, Flash Green, Off | High (75%) 60 seconds Solid Green |
| Location ID | | |

4.6.2 Sensors

This menu allows you to set various items for gas, alarm levels, and mA output connected to the sensor.

Gas-related setting items such as gas, unit& range, and alarms depend on the sensor. The “Gas” and “Unit & Range” setting menus are only enabled if the sensor supports them.

| Item | Description | Default | Range |
|--------------|---|-------------------|-------|
| Gas | It provides the ability to choose the target gas from the detectable gas list, which depends on the sensor. | Depends on sensor | |
| Unit & Range | Set gas unit and measuring range. Only the unit or range setting menu is enabled depending on the sensor. | Depends on sensor | |
| Alarms | It allows you to set alarm levels, trigger directions, latch options, and alarm delays. Alarms 1 and 2 have separate settings except for the Alarm delay. | Depends on sensor | |

| Item | Description | Default | Range |
|--------------------|---|--|--|
| mA output | <ul style="list-style-type: none"> • Activation • Inhibit level • Warning level • Over-range level <p>It provides the ability to set up current output connected to the sensor.</p> | <p>Enable</p> <p>2.0 mA</p> <p>3.0 mA</p> <p>21.0 mA</p> | <p>Enable/Disable</p> <p>1.0 to 3.5 mA</p> <p>1.0 to 4.0 mA</p> <p>20 to 22 mA</p> |
| Deadband | It enables or disables the reading deadband (blank zone). The deadband is a range of values where the gas reading is displayed as zero. | Enable | |
| Test & Calibration | <ul style="list-style-type: none"> • Calibration Notification • Calibration Interval • Bump Test Notification • Bump Test Interval <p>It allows users to set notifications and intervals for gas calibration and bump tests. The transmitter will warn when the interval is reached if notification is enabled. Notification (due warning) only occurs during weekday business hours: Monday to Friday, 9:00 to 17:00</p> | <p>Disable</p> <p>180 days</p> <p>Disable</p> <p>90 days</p> | <p>Enable/Disable</p> <p>1 to 365 days</p> <p>Enable/Disable</p> <p>1 to 90 days</p> |

4.6.3 Inhibit & Fault

| Item | Description | Default |
|---------------------|--|------------|
| Inhibit Timeout | Maximum transmitter inhibits holding time when the user turns on inhibit: 5 to 480 minutes (8 hours) | 15 minutes |
| Temperature Warning | This option controls whether temperature-related warnings and faults are reported. If this option is disabled, all temperature-related warnings and faults from the transmitter and sensors will not be reported(occurred). | Enable |
| Fault Latch | Fault and warning latching enable/disable option. If the option is enabled, the fault or warning does not disappear even if the fault or warning condition is cleared. | Latching |
| Easy Reset | The easy reset option controls whether or not administrator privileges is requested to reset all (alarm, fault, and warnings) on the home screen. Enable - Not required administrator password. Disable - Required administrator password. | Enable |

4.6.4 HART (FSK) Communication

The OmniPoint can communicate with and display information for three sensors at a time. The OmniPoint transmitter generates up to three discrete analog outputs, one for each sensor connected to the transmitter.

The analog output associated with Channel/Sensor 1 also has the digital HART communication superimposed on the analog signal. The digital HART communication carries information for all sensors. A current loop must be formed on the mA output of channel 1 for HART communication.

| Item | Description | Default |
|---------|--|--------------|
| Mode | It provides the ability to select communication mode between “Peer to Peer” and “Muti-drop.” | Peer to Peer |
| Address | It provides the ability to set the device address between 0 and 63. | 0 |

4.6.5 MODBUS RTU Communication

This menu is enabled when the MODBUS RTU module is installed on the transmitter.

| Item | Description | Default |
|-----------|--|----------|
| Slave ID | Set device(transmitter) slave ID between 1 and 247 for MODBUS RTU communication. | 1 |
| Baud Rate | Select communication speed (baud rate) 2400 bps, 4800 bps, 9600 bps, 19200 bps, 38400 bps, 57600 bps, 115200 bps | 9600 bps |
| Stop Bits | Set stop bits. 1 bit, 2 bits | 1 |
| Parity | Set parity. No, Even, Odd | Even |

4.6.6 Security

- This menu allows setting/resetting the passcode of the Operator and Administrator.
- Administrator passcode must be set by the user at the first power on.
- Operator passcode can be set by the logged-in user with Admin privileges.
- If the users forget the Admin password, they should ask the Honeywell Service Engineer for help.
- The Honeywell Service Engineer can log in with the Honeywell Service account and reset the Admin password for the device

| Item | Description |
|-------------------|--------------------------------|
| Operator Passcode | Set passcode for Operator |
| Admin. Passcode | Set passcode for Administrator |

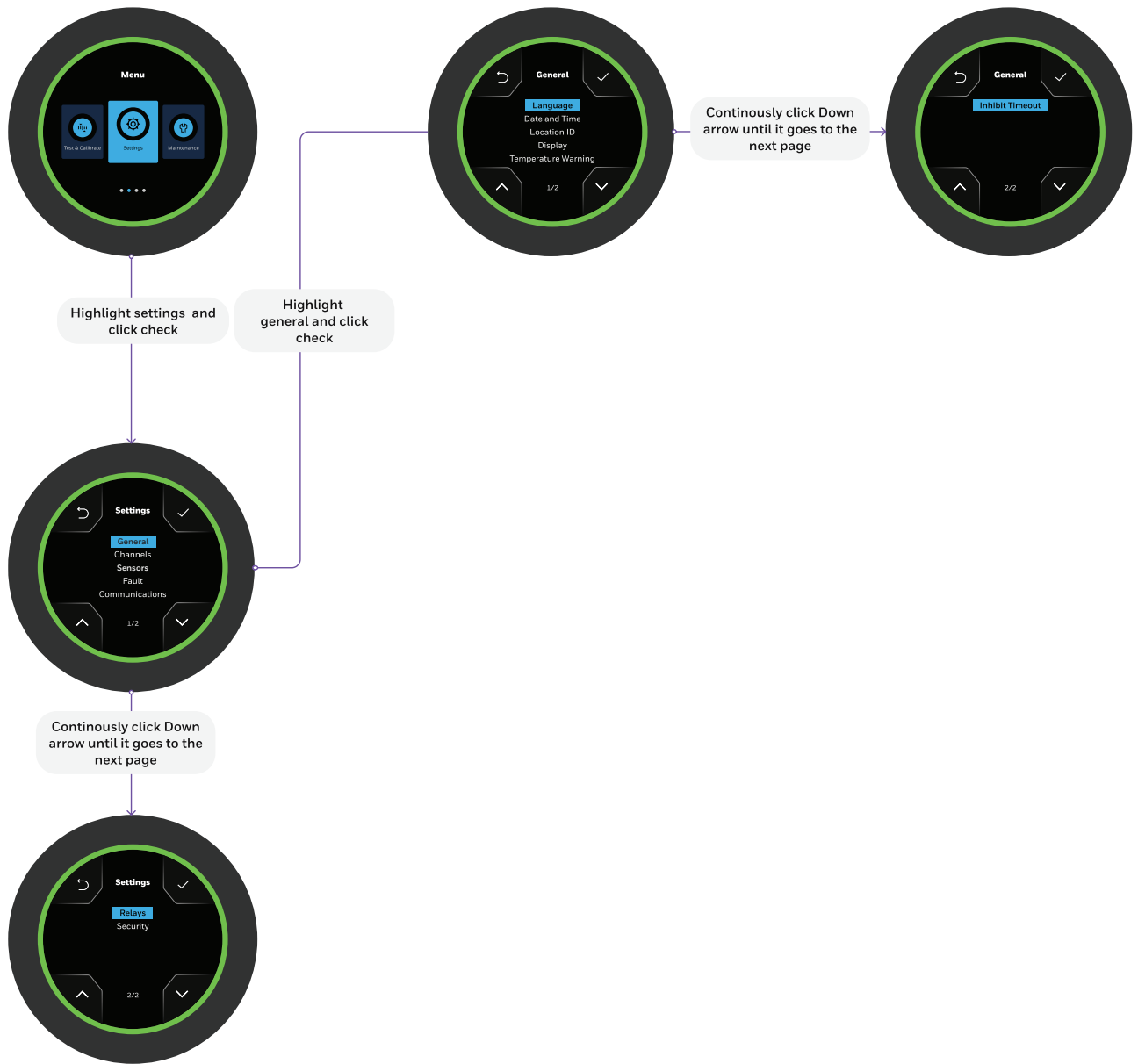

4.7 View Information

Tap  (lower left button) to open the **Information** menu. Select any of the following options:

| | |
|------------------------------|--|
| Event History | History of Alarms, Faults, Warning and Information |
| Calibration History | History of gas calibration |
| System Date / Time | Date and time of the instrument |
| Channel 1, 2, 3 | Sensor information about each channel (Type, S/N, Temperature, FW version, DB version, Gas, measuring range, Alarm 1, Alarm 2) |
| Transmitter Data | Transmitter information (S/N, Location ID, Temperature) |
| Relays | Configuration information about each relay (Link, Energized/De-energized, Acknowledge enable/disable) |
| Field Communication Settings | Configuration information about each digital communication (MODBUS RTU, HART) |
| QR Code | QR code for BLE connection |
| About | General information (Main FW version, Interface FW version, UI version, Key FW version) |

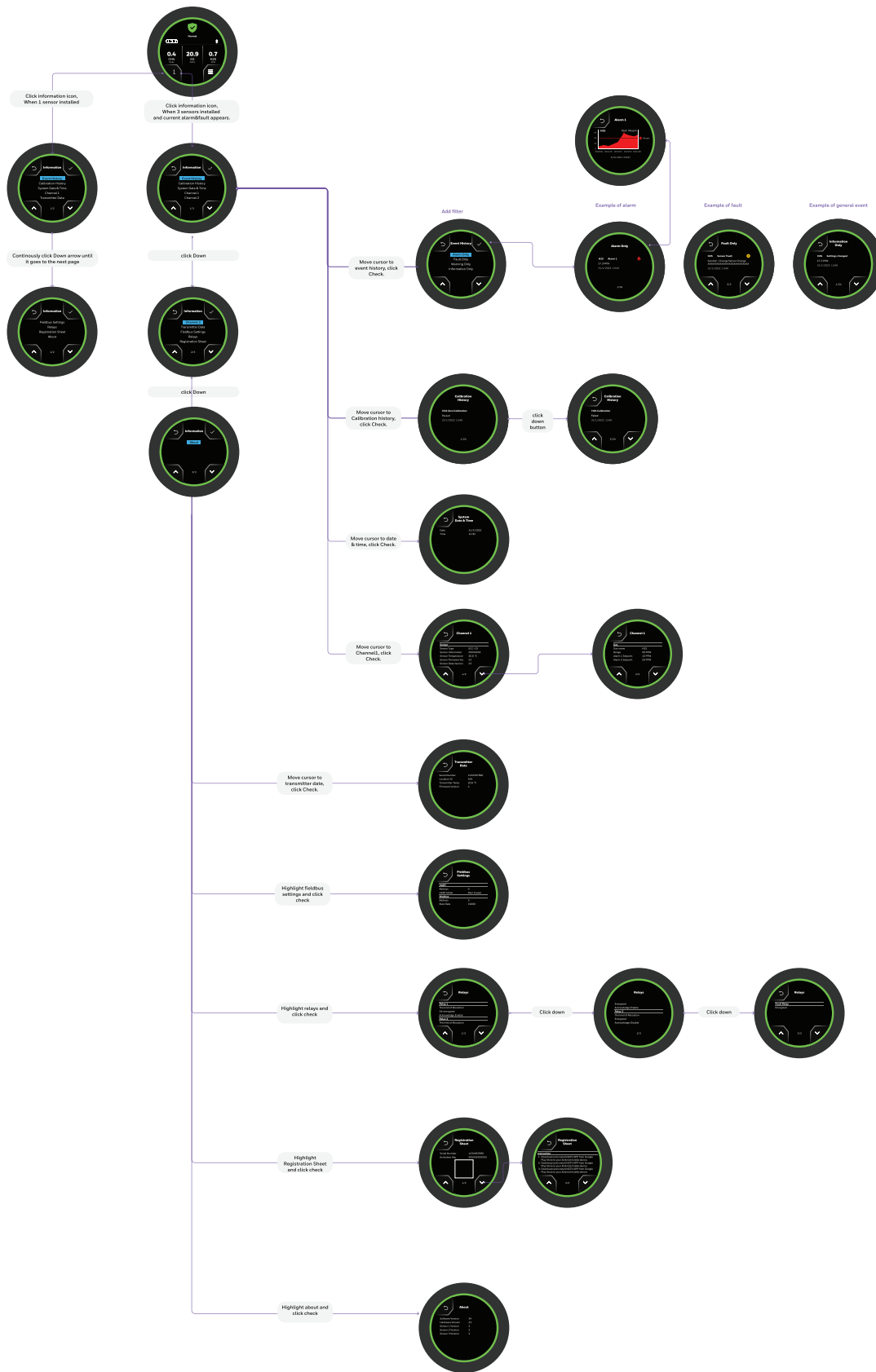

4.8 Channel Setting

- The OmniPoint can connect (install) up to three sensors (2 OmniPoint and one Optima Plus) and has three current outputs that can be linked to these sensors.
- **This menu lets you connect a sensor to a physical mA output or connect a desired sensor to the output.**
- Use the channel setting menu to change the assigned channel without changing the sensor's physical wiring to the transmitter.
- Disabling a channel disables the sensor and its associated mA output.
- By default, physical mA output channels are assigned in the order that sensors are installed.

- For example, if you initially connect only Optima (at first boot), the mA output is automatically connected to mA Ch.1.
- When all three sensors are connected at first boot, output channels are assigned as follows:

| Sensor input | mA channel |
|--------------|------------|
| Sensor 1 | mA Ch. 1 |
| Sensor 2 | mA Ch. 2 |
| IR (Optima) | mA Ch. 3 |

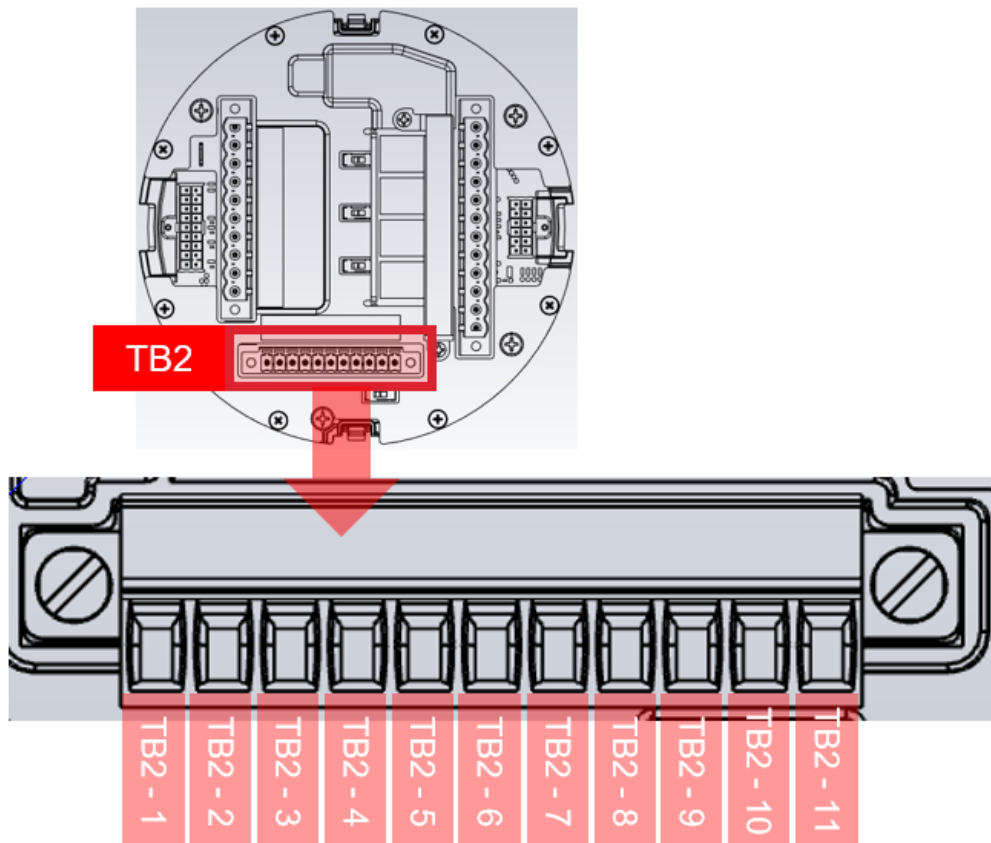

1. Select a Channel to set.



2. Select **Enable** to assign the sensor to the channel or select **Disable** to turn off the sensor and mA output assigned to the channel.



3. Select which sensor to connect to the selected channel.
If you select a sensor assigned to another channel, the previously assigned channel is automatically deactivated.
If you want to activate only the sensor and disable the connected 4-20mA output, disable it using the mA output setting menu in the sensor menu. (**Settings > Sensor > mA output**).



4.9 Inhibit

1. Tap  and select **Inhibit**.
2. Select **ON** or **OFF**



4.10 Transmitter Menu Navigation

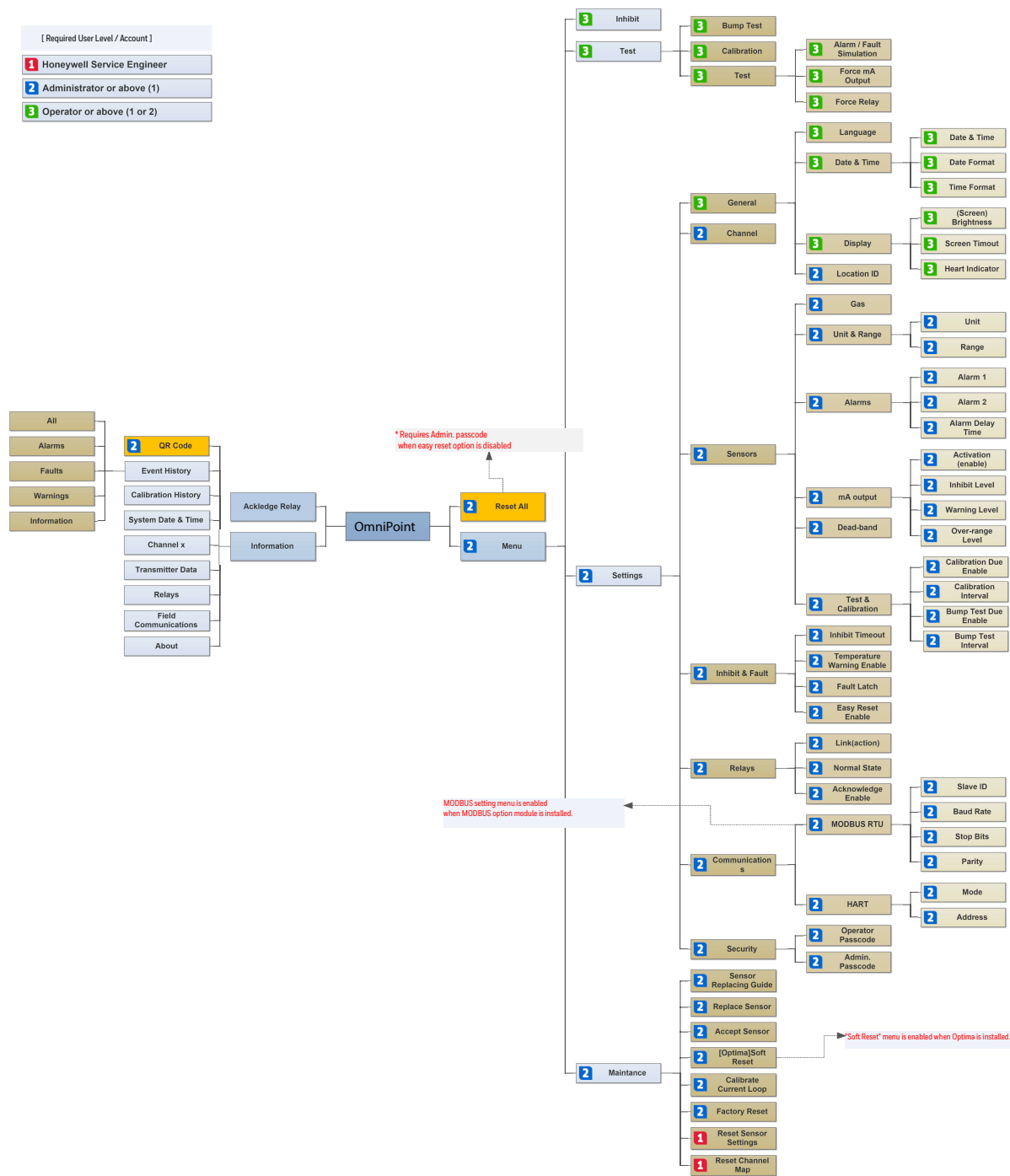

5.1 Maintenance Menu

Tap  and select **Maintenance**



Select any of the following sub menus:

| Sub menu | Description |
|------------------------|---|
| Sensor Replacing Guide | Replace the sensor guide |
| Replace the sensor | Replace each sensor |
| Accept sensor | Accept of changed sensor |
| Soft Reset | Reset Optima in a software manner |
| Calibrate current loop | Calibrate mA output of each channel |
| Factory Reset | Reset all settings as factory configuration |

5.2 Replace an XPIS sensor

1. Select the **Maintenance** menu
2. Select **Replace Sensor**.
3. Select the sensor to be replaced from the screen and tap ▼
4. Remove the current sensor and install a new sensor.

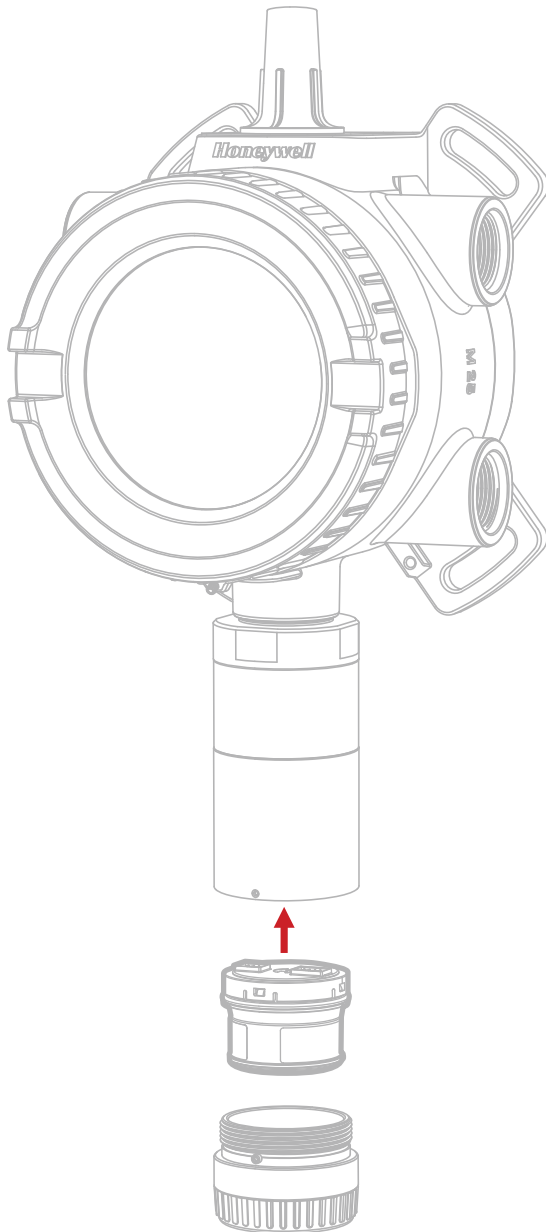

5. Follow onscreen instructions.

5.3 Replace an XP sensor

1. Power off the OmniPoint transmitter.
2. Remove the current sensor and install a new sensor.

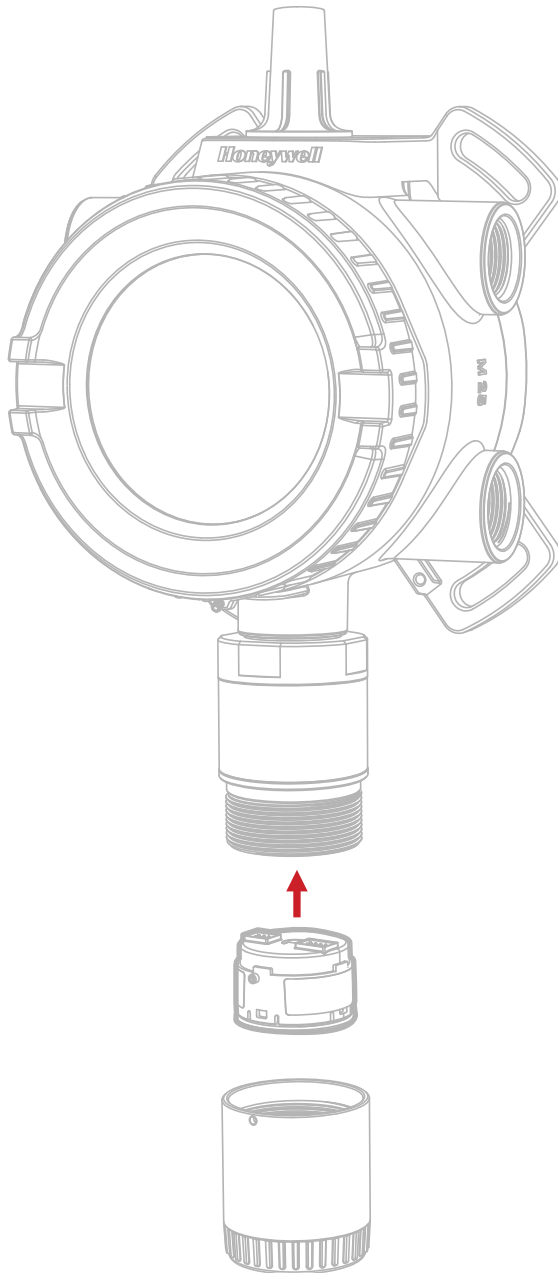

3. Power on the OmniPoint transmitter.
4. The maintenance icon is shown on the display and a sensor mismatch fault is generated.
5. Select **Accept Sensor** in the Maintenance menu.
6. Follow the onscreen instructions.

5.4 Replace an Optima sensor

1. Power off the OmniPoint transmitter.
2. Remove the top cover.
3. Unwire the current Optima from the terminal block.
4. Wire the new Optima to the terminal block.

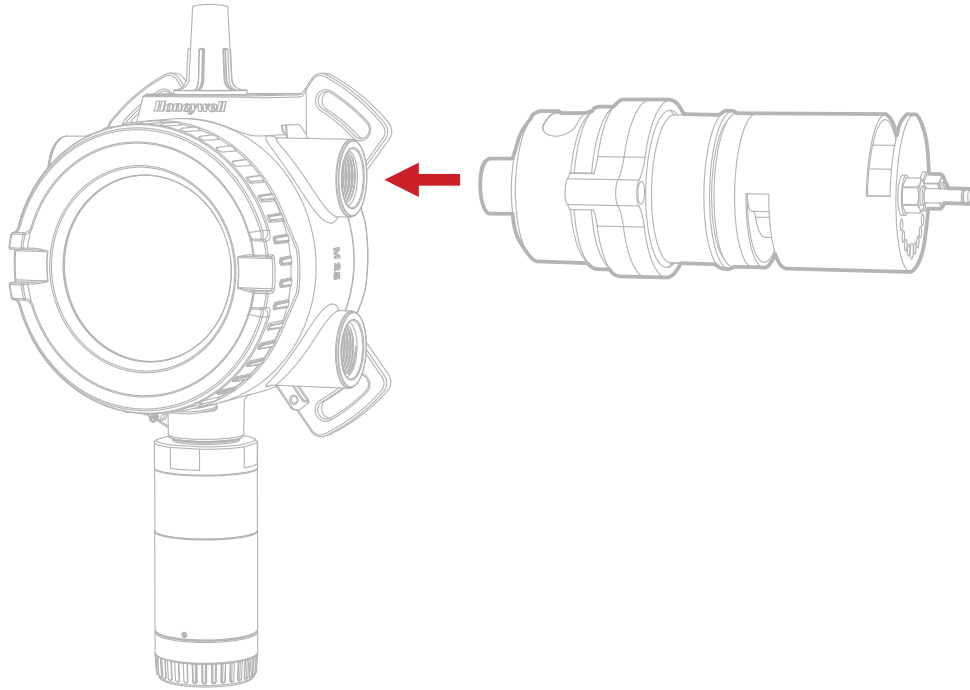

5. Fit the top cover.
6. Power on the OmniPoint transmitter.
7. The change icon on the transmitter's screen generates a sensor mismatch fault.
8. Select **Maintenance**.
9. Select **Accept Sensor**.
10. Follow onscreen instructions.

6.1 Modbus Register Map

| Holding Register Address | Parameter | | Data Type | Description |
|--------------------------|------------------------------------|----------------|------------|--|
| | High byte | Low Byte | | |
| 40001 | OmniPoint transmitter type | Modbus address | unit16 | Transmitter type to facilitate automatic identification. Repeated Modbus Address |
| 40002 | heart beat | | unit16 | This Heartbeat is provided to facilitate detection of communications problems in programming |
| 40003 | sensor type of channel 1 | | byte | The meaning of this datum is as enumerated below 1 mV Bridge / legacy mV sensor 2 Electrochemical Cell with toxic cartridge (XNX/ XCD, legacy ECC) 3 Electrochemical Cell with O2 cartridge (XNX/ XCD, legacy ECC) 4 Searchpoint Optima Plus* 5 Searchline Excel 6 generic mA input 7 FL/IR sensor - OmniPoint Smart Sensor* 8 ECC toxic/O2 sensor - OmniPoint Smart Sensor* 9-255 for future expansion |
| 40004 | sensor type of channel 2 | | byte | see above |
| 40005 | sensor type of channel 3 | | byte | see above |
| 40006 | gas name of channel 1 | | string[25] | target gas name of sensor channel 1 |
| 40019 | gas name of channel 2 | | string[25] | target gas name of sensor channel 2 |
| 40032 | gas name of channel 3 | | string[25] | target gas name of sensor channel 3 |
| 40045 | alarm 1 level of sensor channel 1 | | float32 | configured alarm 1 level of sensor channel 1 |
| 40047 | alarm 2 level of sensor channel 1 | | float32 | configured alarm 2 level of sensor channel 1 |
| 40049 | alarm 1 level of sensor channel 2 | | float32 | configured alarm 1 level of sensor channel 2 |
| 40051 | alarm 2 level of sensor channel 2 | | float32 | configured alarm 2 level of sensor channel 2 |
| 40053 | alarm 1 level of sensor channel 3 | | float32 | configured alarm 1 level of sensor channel 3 |
| 40055 | alarm 2 level of sensor channel 3 | | float32 | configured alarm 2 level of sensor channel 3 |
| 40057 | sensor channel 1 gas concentration | | float32 | The reported gas concentration in current measurement units. For example, methane at 50% LEL would be reported as 50.0 here. This concentration is forced to zero during gas calibration. |
| 40059 | sensor channel 2 gas concentration | | float32 | |
| 40061 | sensor channel 3 gas concentration | | float32 | |
| 40063 | sensor channel 1 measurement unit | | byte | The meaning of this datum is as enumerated below: 0 default 1 mg/m3* 2 g/m3 3 %vol* 4 ppm* 5 %LEL* 6 UEG 7 Ratio 8 %LEL*M 9 ppm*m 10 EG*m 11 %vol* meter 12 μmole / mole 13 generic unit (user configured unit) 14 ppb 15-255 for future expansion |
| 40064 | sensor channel 2 measurement unit | | byte | |
| 40065 | sensor channel 3 measurement unit | | byte | |

*Available at initial launch

| Holding Register Address | Parameter | | Data Type | Description |
|--------------------------|--|----------|-----------|---|
| | High byte | Low Byte | | |
| 40075 | transmitter status | | unit32 | Transmitter status bit description bit 0 boot up (0: booting up, 1: normal) bit 1 inhibited (0: normal, 1: inhibited) bit 2 alarm 1 bit 3 alarm 2 bit 4 latched alarm 1 bit 5 latched alarm 2 bit 6 over-range bit 7 warning bit 8 fault bit 9 latched warning bit 10 latched fault bit 11 bump test bit 12 (gas) calibration bit 13 Reserved for internal use bit 14 Reserved for internal use bit 15 Reserved for internal use bit 16 alarm 1 simulation bit 17 alarm 2 simulation bit 18 fault simulation bit 19 warning simulation bit 20 force loop current bit 21 force relay bit 22 Reserved bit 23 BLE connected bit 24 Reserved for internal use bit 25 Reserved for internal use bit 26 Reserved for internal use bit 27 updating FW - interface or main bit 28 for future expansion bit 29 updating UI (screens) bit 30 updating FW - touch bit 31 for future expansion |
| 40077 | sensor channel 1 status | | unit32 | sensor status bit description bit 0 enabled (0: disabled, 1: enabled) bit 1 warm-up (0: normal, 1: warm-up) bit 2 inhibited (0: normal, 1: inhibited) bit 3 alarm 1 bit 4 alarm 2 bit 5 latched alarm 1 bit 6 latched alarm 2 bit 7 over-range bit 8 warning bit 9 fault bit 10 latched warning bit 11 latched fault bit 12 (gas) calibration bit 13 alarm 1 simulation bit 14 alarm 2 simulation bit 15 sensor data updating bit 16 sensor changed (mismatch) bit 17 FW updating bit 18 sensor installed status (0: not installed, 1: installed) bit 19 ~ for future expansion bit 24 calibration overdue bit 25 bump test overdue bit 26 ~ for future expansion |
| 40079 | sensor channel 2 status | | unit32 | |
| 40081 | sensor channel 3 status | | unit32 | |
| 40083 | active transmitter fault/warning code | | unit16 | This is the integer representation of the fault/warning status. If the transmitter has no fault and no warning, the value is 0. If any fault exists this will take a value in the range 1001 to 1999. Otherwise, if any warning exists, this will take a value in the range 1 to 999. If there are active multiple faults, the latest fault will be returned. If there are both fault and warning the latest of fault will be returned. |
| 40084 | active sensor channel 1 fault/warning code | | unit16 | This is the integer representation of the fault/warning status. If sensor channel 1 has no fault and no warning, the value is 0. If any fault exists this will take a value in the range 1001 to 1999. Otherwise, if any warning exists, this will take a value in the range 1 to 999. If there are active multiple faults, the latest fault will be returned. If there are both fault and warning the latest of fault will be returned. |
| 40085 | active sensor channel 2 fault/warning code | | unit16 | This is the integer representation of the fault/warning status. If sensor channel 2 has no fault and no warning, the value is 0. If any fault exists this will take a value in the range 1001 to 1999. Otherwise, if any warning exists, this will take a value in the range 1 to 999. If there are active multiple faults, the latest fault will be returned. If there are both fault and warning the latest of fault will be returned. |
| 40086 | active sensor channel 3 fault/warning code | | unit16 | This is the integer representation of the fault/warning status. If sensor channel 3 has no fault and no warning, the value is 0. If any fault exists this will take a value in the range 1001 to 1999. Otherwise, if any warning exists, this will take a value in the range 1 to 999. If there are active multiple faults, the latest fault will be returned. If there are both fault and warning the latest of fault will be returned. |
| 40087 | remaining life days of sensor channel 1 | | int16 | This indicates the time remaining before sensor on channel 1 must be replaced. This register value is valid only for OmniPoint smart sensor. |
| 40088 | remaining life days of sensor channel 2 | | int16 | This indicates the time remaining before sensor on channel 2 must be replaced. This register value is valid only for OmniPoint smart sensor. |
| 40089 | remaining life days of sensor channel 3 | | int16 | This indicates the time remaining before sensor on channel 3 must be replaced. This register value is valid only for OmniPoint smart sensor. |

| Holding Register Address | Parameter | | Data Type | Description |
|--------------------------|---|--|-----------|--|
| | High byte | Low Byte | | |
| 40090 | calibration due days of sensor channel 1 | | int16 | This indicates the time remaining before sensor on channel 1 must be calibrated. |
| 40091 | calibration due days of sensor channel 2 | | int16 | This indicates the time remaining before sensor on channel 2 must be calibrated. |
| 40092 | calibration due days of sensor channel 3 | | int16 | This indicates the time remaining before sensor on channel 3 must be calibrated. |
| 40093 | transmitter Temperature | | int16 | Temperature of the OmniPoint transmitter in Celsius. |
| 40094 | sensor 1 Temperature | | int16 | Temperature of sensor channel 1 in x10 Celsius |
| 40095 | sensor 2 Temperature | | int16 | Temperature of sensor channel 2 in x10 Celsius |
| 40096 | sensor 3 Temperature | | int16 | Temperature of sensor channel 3 in x10 Celsius |
| 40098 | date and Time | | string18 | Format is "mm/dd/yy hh:mm:ss" |
| 40107 | mA channel 1 output | | float32 | The current produced by the OmniPoint in mA. |
| 40109 | mA channel 2 output | | float32 | The current produced by the OmniPoint in mA. |
| 40111 | mA channel 3 output | | float32 | The current produced by the OmniPoint in mA. |
| 40113 | transmitter supplied voltage: 24V | | unit16 | The voltage supplied to the OmniPoint at the nominal 24.0 volt input, in millivolts. |
| 40114 | transmitter operating voltage: 3.3V | | unit16 | The voltage on a nominal 3.3 volt operating in the OmniPoint, in millivolts. |
| 40115 | transmitter operating voltage: 5V | | unit16 | The voltage on a nominal 5 volt operating in the OmniPoint, in millivolts. |
| 40116 | transmitter safety voltage: 5V | | unit16 | The voltage on a nominal 5 volt safety in the OmniPoint, in millivolts. |
| 40117 | sensor channel 1 supplied voltage: 5V - 24V | | unit16 | The voltage on a nominal 5 volt supply in sensor channel 1, in millivolts. If sensor channel 1 is Optima Plus or Excel, nominal 24V value supplied to them. |
| 40118 | sensor channel 1 operating voltage: 3.3V - 5V | | unit16 | The voltage on a nominal 3.3 volt operating in sensor channel 2, in millivolts. If sensor channel 1 is Optima Plus or Excel, nominal 5V value. |
| 40119 | sensor channel 2 supplied voltage: 5V - 24V | | unit16 | The voltage on a nominal 5 volt supply in sensor channel 3, in millivolts. If sensor channel 2 is Optima Plus or Excel, nominal 24V value supplied to them. |
| 40120 | sensor channel 2 operating voltage: 3.3V - 5V | | unit16 | The voltage on a nominal 3.3 volt operating in sensor, in millivolts. If sensor channel 2 is Optima Plus or Excel, nominal 5V value. |
| 40121 | sensor channel 3 supplied voltage: 5V - 24V | | unit16 | The voltage on a nominal 5 volt supply in sensor, in millivolts. If sensor channel 3 is Optima Plus or Excel, nominal 24V value supplied to them. |
| 40122 | sensor channel 3 operating voltage: 3.3V - 5V | | unit16 | The voltage on a nominal 3.3 volt operating in sensor, in millivolts. If sensor channel 3 is Optima Plus or Excel, nominal 5V value. |
| 40123 | alarm 1 direction for sensor channel 1 | alarm 2 direction for sensor channel 1 | unit16 | Configured alarm trigger option(direction) of sensor channel 1 The meaning of this datum is as enumerated below. 0 disabled 1 rising 2 falling |
| 40124 | alarm 1 direction for sensor channel 2 | alarm 2 direction for sensor channel 2 | unit16 | see above |
| 40125 | alarm 1 direction for sensor channel 3 | alarm 2 direction for sensor channel 3 | unit16 | see above |
| 40126 | alarm 1 latching for sensor channel 1 | alarm 2 latching for sensor channel 1 | unit16 | configured alarm latching option(direction) of sensor channel 1 The meaning of this datum is as enumerated below. 0 disabled 1 enabled |
| 40127 | alarm 1 latching for sensor channel 2 | alarm 2 latching for sensor channel 2 | unit16 | see above |
| 40128 | alarm 1 latching for sensor channel 3 | alarm 2 latching for sensor channel 3 | unit16 | see above |
| 40129 | relay 1 link option | relay 2 link option | unit16 | Indicate configured relays links to which alarm. The meaning of this datum is as enumerated below 0 disabled 1 alarm 1 for any sensor 2 alarm 2 for any sensor 3 any alarm for sensor channel 1 4 any alarm for sensor channel 2 5 any alarm for sensor channel 3 |
| 40130 | relay 3 link option | | unit16 | see above |
| 40131 | relay 1 operation at normal | relay 2 operation option at normal | unit16 | Indicates configured relay operation in normal state. The meaning of this datum is as enumerated below 0 de-energized 1 energized |
| 40132 | relay 3 operation at normal | | unit16 | see above |
| 40133 | relay 1 acknowledge enable | relay 2 acknowledge enable | unit16 | Indicates configured relay acknowledge enable option. The meaning of this datum is as enumerated below. 0 disabled 1 enabled |
| 40134 | relay 3 acknowledge enable | | unit16 | see above |
| 40135 | inhibit current of mA out 1 | | float32 | Indicates configured inhibit current value on channel 1, in mA |
| 40137 | warning current of mA out 1 | | float32 | Indicates configured warning current value on channel 1, in mA |
| 40139 | fault current of mA out 1 | | float32 | Indicates configured fault current value on channel 1, in mA |
| 40141 | over-range current of mA out 1 | | float32 | Indicates configured over-range current value on channel 1, in mA |
| 40147 | inhibit current of mA out 2 | | float32 | Indicates configured inhibit current value on channel 2, in mA |
| 40149 | warning current of mA out 2 | | float32 | Indicates configured warning current value on channel 2, in mA |
| 40151 | fault current of mA out 2 | | float32 | Indicates configured fault current value on channel 2, in mA |
| 40153 | over-range current of mA 2 | | float32 | Indicates configured over-range current value on channel 2, in mA |
| 40159 | inhibit current of mA out 3 | | float32 | Indicates configured inhibit current value on channel 3, in mA |
| 40161 | warning current of mA out 3 | | float32 | Indicates configured warning current value on channel 3, in mA |
| 40163 | fault current of mA out 3 | | float32 | Indicates configured fault current value on channel 3, in mA |
| 40165 | over-range current of mA 3 | | float32 | Indicates configured over-range current value on channel 3, in mA |
| 40171 | calibration due enable of sensor channel 1 | | unit16 | Indicates configured calibration due enable option of sensor channel 1 0: disable, 1: enable |
| 40172 | calibration interval of sensor channel 1 | | unit16 | Indicates configured calibration interval of sensor channel 1, days |
| 40173 | calibration due enable of sensor channel 2 | | unit16 | Indicates calibration due enable option of sensor channel 2 0: disable, 1: enable |
| 40174 | calibration interval of sensor channel 2 | | unit16 | Indicates configured calibration interval of sensor channel 2, days |
| 40175 | calibration due enable of sensor channel 3 | | unit16 | Indicates calibration due enable option of sensor channel 3 0: disable, 1: enable |
| 40176 | calibration interval of sensor channel 3 | | unit16 | Indicates configured calibration interval of sensor channel 3, days |
| 40177 | bump test due enable of sensor channel 1 | | unit16 | Indicates configured bump test due enable option of sensor channel 1 0: disable, 1: enable |

| Holding Register Address | Parameter | | Data Type | Description |
|--------------------------|--|----------|------------|--|
| | High byte | Low Byte | | |
| 40178 | bump test interval of sensor channel 1 | | unit16 | Indicates configured bump test interval of sensor channel 1, days |
| 40179 | bump test due enable of sensor channel 2 | | unit16 | Indicates configured bump test due enable option of sensor channel 2 0: disable, 1: enable |
| 40180 | bump test interval of sensor channel 2 | | unit16 | Indicates configured bump test interval of sensor channel 2, days |
| 40181 | bump test due enable of sensor channel 3 | | unit16 | Indicates configured bump test due enable option of sensor channel 3 0: disable, 1: enable |
| 40182 | bump test interval of sensor channel 3 | | unit16 | Indicates configured bump test interval of sensor channel 3, days |
| 40213 | location ID | | string[20] | Configured location ID of the OmniPoint transmitter |
| 40223 | transmitter serial number | | string[20] | OmniPoint transmitter serial number |
| 40233 | sensor channel 1 serial number | | string[14] | Serial number of sensor channel 1 if OmniPoint Smart Sensor is installed. |
| 40240 | sensor channel 2 serial number | | string[14] | Serial number of sensor channel 2 if OmniPoint Smart Sensor is installed. |
| 40247 | sensor channel 3 serial number | | string[14] | Serial number of sensor channel 3 if OmniPoint Smart Sensor is installed. |
| 40254 | transmitter FW version | | byte[3] | Firmware version of OmniPoint Transmitter. 1st byte: major, 2nd byte: minor, 3rd byte: build number |
| 40256 | sensor channel 1 FW version | | byte[3] | Firmware version of sensor channel 1 |
| 40258 | sensor channel 2 FW version | | byte[3] | Firmware version of sensor channel 2 |
| 40260 | sensor channel 3 FW version | | byte[3] | Firmware version of sensor channel 3 |
| 40262 | sensor channel 1 name | | string[20] | Sensor name of channel 1 |
| 40272 | sensor channel 2 name | | string[20] | Sensor name of channel 2 |
| 40282 | sensor channel 3 name | | string[20] | Sensor name of channel 3 |
| 40292 | sensor channel 1 user full-scale | | float | Indicates configured full-scale of sensor channel 1 |
| 40294 | sensor channel 2 user full-scale | | float | Indicates configured full-scale of sensor channel 2 |
| 40296 | sensor channel 3 user full-scale | | float | Indicates configured full-scale of sensor channel 3 |
| Writing Registers | | | | |
| 41001 | reset all alarms & faults | | unit16 | Reset all alarm & faults Write (send) non zero value to reset all alarms & faults |
| 41002 | start inhibit | | unit16 | Start transmitter inhibit Write (send) non zero value to execute command: start inhibit |
| 41003 | end inhibit | | unit16 | End transmitter inhibit Write (send) non zero value to execute command: stop inhibit |

6.2 Warning Information

| Index | Warning | Applicable Sensors | Required Manual Reset ^{Note.1} | Event History Data | Action for Resolution |
|-------|--|--------------------|---|-------------------------------------|---|
| [1] | 24VDC Supply Bad | All | | OmniPoint supply voltage (mV) | Check wire of 24V power supply to OmniPoint as well as power supply operation. Check location for heat source. Fit with sunshade or other protection. Change location of OmniPoint. |
| [2] | Exceed transmitter operating temperature | All | | OmniPoint temperature(Celsius) | Check "Information > Transmitter Data" to ensure temperature is being measured properly. Check location for heat source. Fit with sunshade or other protection. Change location of OmniPoint. |
| [3] | Exceed sensor operating temperature | All | | Sensor temperature(Celsius) | Check "Information > Channel X" to ensure temperature is being measured properly. Check location for heat source. Fit with sunshade or other protection. Change location of OmniPoint. |
| [4] | Negative drift | All | | Gas concentration | Check sensor location for external interference. Perform zero calibration. If problem persists after zero calibration and no interference exists, replace sensor. |
| [5] | Calibration overdue | All | | Overdue days | Time since the last calibration has exceeded a user configured calibration interval . Performing a successful gas calibration will clear the condition. This warning is disabled by setting the "Calibration Notification" to disable. Since setting can be made for each sensor, just disable "Calibration Notification" in desired sensor menu. |
| [6] | [Optima] Sensor 24VDC supply bad | Optima Plus | | Optima Plus supply voltage(mV) | Check the wire of the 24V power supply to OmniPoint as well as the power supply operation. Also, check the wiring between OmniPoint and Optima |
| [7] | [Optima]Sensor path obscured | Optima Plus | | | Check location for external interference. Check sensor for dirty window. |
| [9] | [Optima]Sensor internal lamp issue | Optima Plus | O | Optima Plus Error code | Remove and return to Honeywell for repair. |
| [12] | [Optima] sensor (current) loop failure | Optima Plus | O | sensor channel, mA input (mA) | Check that the supply voltage is stable. Check wiring between Optima and OmniPoint. Check the loop impedance of the wiring. Check that SW4(mA input mode, Source/sink) is set correctly. If the switch setting needs to be changed, power down the transmitter before changing it. Once the problem has been solved, a Soft Reset must be performed. |
| [13] | [Optima]Excessive float | Optima Plus | | | Check sensor location for external interference, check sensor for operation and re-zero where appropriate. |
| [14] | Bump test overdue | All | | Overdue days | Time since the last bump test has exceeded a user configured bump test interval . Performing a successful bump test will clear the condition. This warning is disabled by setting the "Bump Test Notification" to disable. Since setting can be made for each sensor, just disable "Bump Test Notification" in desired sensor menu. |
| [15] | Force mA timeout | All | O | mA output channel, timeout(minutes) | Indicates that a forced mA condition was left on for more than 15 minutes. No action required as mA operation will be returned to normal automatically. |
| [16] | Force relay timeout | All | O | Relay number, timeout (minutes) | Indicates that a forced the relay condition was left on for more than 15 minutes. No action required as relay operation will be returned to normal automatically. |

6.3 Fault Information

| Index | Faults | Applicable Sensors | Required Manual Reset | Event History Data | Action for Resolution |
|-------|--|--------------------------|-----------------------|---|---|
| [1] | Unexpected sensor reset | All | | Sensor channel | If repeated, check supply voltage, cable loop impedance and terminal connection. |
| [2] | Exceed transmitter operating temperature | All | | OmniPoint temperature(Celsius) | Check location for heat source. Fit with sunshade or other protection. Change location of OmniPoint. Check "Information > Transmitter Data" to ensure temperature is being measured properly. |
| [3] | 24DC supply bad | All | | OmniPoint supply voltage(mV). | Check wire of 24V power supply to OmniPoint as well as power supply operation |
| [4] | Real time clock failure | All | | Total seconds since Dec. 31, 2020 | Either clock was incorrectly set or the battery for the clock has failed. |
| [5] | Internal SW failure | All | 0 | | Contact Honeywell's Service Department. |
| [6] | mA output loop failure | All | 0 | Channel, Measured current (mA) | Check wiring mA output from OmniPoint. Check isolation mode switch of failed output channel. |
| [7] | Sensor FW version mismatch | All | 0 | FW Version: Major, Minor, Build | Please update sensor FW for XP or XPIS sensor if BLE option is available. If it occurs on Optima Plus or BLE option is not available, contact Honeywell's Service Department. |
| [8] | Negative drift | All | | Gas concentration | Check sensor location for external interference. Perform zero calibration. If problem persists after zero calibration and no interference exists, replace sensor. |
| [9] | [Optima/ Excel]sensor 24VDC supply bad | Optima Plus | | Optima Plus supply voltage(mV) | Check the wire of the 24V power supply to OmniPoint as well as the power supply operation. Also, check wiring between OmniPoint and Optima |
| [11] | [Optima] sensor internal lamp issue | Optima Plus | 0 | Optima Plus Error code | Remove and return to Honeywell for repair. |
| [12] | Sensor internal failure | | | Optima Plus: Error code from Optima Plus OmniPoint sensor: Sensor SW Error Code ^{*Note 2} | Remove and return to Honeywell for repair. |
| [13] | [optima] sensor (current) loop failure | Optima Plus | 0 | Measured input current (mA) | Check that the supply voltage is stable. Check wiring between Optima and OmniPoint. Check the loop impedance of the wiring. Check that SW4 (mA input mode, Source/sink) is set correctly. If the switch setting needs to be changed, power down the transmitter before changing the switch setting. Once the problem has been resolved, a Soft Reset must be performed. |
| [14] | Sensor HW failure | OmniPoint Sensors | | OmniPoint sensor: Sensor HW Error Code ^{*Note 3} | Remove and return to Honeywell for repair. |
| [15] | No sensor | All | | | Check the wiring between OmniPoint and sensor. |
| [16] | sensor data corruption | OmniPoint Sensors | | | Remove and return to Honeywell for repair. |
| [17] | sensor mismatch | OmniPoint Sensors | | Setting sensor type, Installed sensor type ^{*Note4} | Mismatch between the setting sensor and installed sensor. Check the sensor installed, and run the sensor replacement or acceptance in the maintenance menu. |
| [18] | Exceed sensor operating temperature | All | | Sensor temperature(Celsius) | Check location for heat source. Fit with sunshade or other protection. Change location of OmniPoint. Check "Information > Channel x" to ensure temperature is being measured properly. |
| [19] | [Optima] sensor path obscured | Optima Plus | | | Check location for external interference. |
| [22] | Sensor cell failure | OmniPoint Sensors | | | Check sensor for dirty windows. |
| [23] | [Optima] mA input indicates fault | Optima Plus | | Measured mA input current (mA) | Replace sensor module. |
| [25] | mV current control failure | OmniPoint FL, IR sensors | 0 | Control voltage(mV, IR sensor) or current (mA, FL sensor) | Please check sensor installation. If repeated, remove and return to Honeywell. |
| [26] | Sensor drift fault | OmniPoint Sensors | | Baseline, Fault Threshold | Perform zero calibration. If problem persists after zero calibration and no interference exists, replace sensor. |
| [27] | Supply voltage bad | OmniPoint Sensors | | measured voltage(mV), target voltage(mV), internal supply voltage type ^{*Note5} | Remove and return to Honeywell for repair. |
| [28] | [Optima] digital gas reading bad | Optima Plus | | Gas concentration transmitted by communication | Check wiring to Optima. In particular, check the white wire between OmniPoint and Optima. Note: power must be cycled to reset this fault after correcting the cause. |
| [29] | [Optima] mA input diagnostic failure | Optima Plus | 0 | mA input current (mA) | Contact Honeywell Service Department. |
| [30] | [Optima] General diagnostics failure | Optima Plus | | Optima Plus: Error code from Optima Plus | Contact Honeywell Service Department. |
| [32] | Unexpected sensor fault | OmniPoint sensors | | OmniPoint sensor error code | If repeated, remove and return to Honeywell. |
| [33] | Watchdog reset | All | 0 | | If repeated, remove and return to Honeywell. |

6.4 Information messages

| Index | Information | Event History Data |
|-------|--|---|
| [1] | Power on | |
| [2] | Reset alarm & faults | Requester ^{Note 6} |
| [3] | Inhibit timeout | Timeout (minutes) |
| [4] | Enter inhibit mode | Requester |
| [5] | Exit inhibit mode | Requester |
| [6] | Acked relay | Sensor channel, Relay ID, Requester |
| [7] | bump test | Gas ID, Peak concentration |
| [8] | zero calibration : success | Sensor channel, Gas ID, Target Gas Concentration |
| [9] | zero calibration : fail | Sensor channel, Gas ID, Gas Concentration |
| [10] | span calibration : success | Sensor channel, Gas ID, Target Gas Concentration |
| [11] | span calibration : fail | Sensor channel, Gas ID, Gas Concentration |
| [12] | sensor replaced | Old sensor type, New sensor type |
| [13] | BLE connected | |
| [14] | BLE disconnected | |
| [15] | mA calibration: success | mA output channel, Current calibration step ^{Note 7} |
| [16] | mA calibration: failed | mA output channel, Current calibration step |
| [17] | interface FW updated: success | Version |
| [18] | interface FW updated: fail | |
| [19] | main FW updated: success | Version |
| [20] | main FW updated: fail | |
| [21] | sensor FW updated: success | Version |
| [22] | sensor FW updated: fail | |
| [23] | smart sensor data updated: success | Version |
| [24] | smart sensor data updated: fail | |
| [27] | certificate updated: success | |
| [28] | certificate updated: fail | |
| [29] | configuration updated : alarm | |
| [30] | configuration updated : gas | |
| [31] | configuration updated: relay | |
| [32] | configuration updated: 4-20mA | |
| [33] | configuration updated: external comm | |
| [34] | configuration updated: channel updated | Channel 1 sensor type, Channel 2 sensor type, Channel 3 sensor type |
| [35] | configuration sync. (recovered) | |
| [36] | configuration mismatch | |
| [37] | changed date /time | |
| [38] | Force 4-20mA : Start | mA output channel, Target current(mA) |
| [39] | Force 4-20mA : end | mA output channel |
| [40] | Force relay : start | Relay ID, Relay test type ^{Note 8} |
| [41] | Force relay : end | Relay ID |
| [42] | UI updated : success | Version |
| [43] | UI updated: fail | |
| [44] | System Restart | |
| [45] | Touch FW updated: success | Version |
| [46] | Touch FW updated: fail | |

***Note 1. Required Manual Reset.**

"Required Manual Reset" means the warning or fault should be cleared/reset by user confirmation(reset) regardless of the fault latching setting.

***Note 2. Sensor Internal Error Code**

1: System initialization fails

2: System Fail

3: Code CRC Fail

4: RAM fail

***Note 3. Sensor HW Error Code**

1 to 4: Not used

5: ADC Fail (internal)

6: ADC Fail (external)

7: Flash memory fail

8: Flash memory fail

9: EEPROM fail

10: Communication module fail

***Note 4. Sensor Type**

0: Unknown, 1: ECC Sensor, 2: FL/IR Sensor, 3: Generic mV, 4: Generic mA, 6: Serchpoint Opima Plus

***Note 5. Internal Supply Voltage Type**

Type is available only for OmniPoint transmitter

0: 5V, 1: Saftey 5V

***Note 6. Requester**

Event requester

0: Local UI, 1: Mobile app, 2: MODBUS RTU, 3: HART, 4: Remote SW

***Note 7. Current Calibration Step**

0: 4mA Calibration, 1: 20mA Calibration

***Note 8. Relay Test Type**

0: de-energized, 1: energized

6.5 Technical Specifications

| GENERAL SPECIFICATIONS | |
|--|---|
| Description | The OmniPoint is a versatile, universal, smart transmitter which provides detection of toxic and combustible hazards in certified area. The OmniPoint is designed for the global market and provides configurable options for creating a gas detection system that integrates into variety of hazardous location including oil and gas refining, chemical and petrochemical plants, and power and energy generation. |
| Material | Enclosure: Five-coat marine finish painted aluminum alloy or 316 stainless steel |
| Weight | Transmitter (enclosure only): Aluminum alloy: 2.48 kg (5.47 lb), 316 stainless steel: 5.37 kg (11.84 lb) Transmitter with display module: Aluminum alloy: 2.78 kg (6.12 lb), 316 stainless steel: 5.70 kg (12.50 lb) XPIS sensor module with cartridge: 0.80 kg (1.76 lb) XP sensor module with cartridge: 0.69 kg (1.52 lb) |
| Mounting | Can be mounted to flat wall surfaces of various types or to pipes using the optional pipe mount kit. The pipe mount kit allows the transmitter to be mounted to pipes from 2 in to 6 in (50 mm to 140 mm) in diameter and includes the pipe mount bracket, four carriage bolts, nuts, and lock washers. The transmitter is configured with five cable/conduit ports built into the housing for wiring and mounting sensors. |
| Cable Entries | Four conduit/cable entries (two right, two left, one bottom). Entry size M25 or 0.75 inch NPT One external antenna entry (top). Entry size M22 |
| ENVIRONMENTAL | |
| IP Rating | IP66/IP67 in accordance with EN60529, NEMA 4X |
| Operating Temperature | -55°C to 75°C (-67°F to 167°F) |
| Operating Humidity | 0 % to 99 %RH (non condensing) |
| Operating Pressure | 90 kPa to 110 kPa |
| Storage Conditions | -55°C to 75°C (-67°F to 167°F), 0 % to 99 %RH (non-condensing) |
| ELECTRICAL | |
| Input Voltage Range | 12 Vdc to 32 Vdc (24 Vdc Nominal) XP (mV, mA) and XPIS sensors 18 Vdc to 32 Vdc (24 Vdc Nominal) Optima/Excel 1.0 |
| Power Consumption | Transmitter : Normal 4.5 watts, Max 8.5 watts XPIS sensor (EC cell) : Max 0.3 watts XP sensor (Catalytic or IR cell) : Max 1.7 watts |
| Visual | 3 inch (76 mm) circular high resolution, full color, TFT display Four capacitive touch keys that provide navigation and other functions. LED ring indicator surrounding the 3 in (76 mm) circular display indicates the device status. (Normal operation: Green, Alarm: Red, Fault/Warning: Yellow, Wireless communication: (Blue) |
| Current Output | 3 channels of fully configurable 4 mA to 20 mA providing current sink, current source and isolated modes of operation to support up to 3 sensors simultaneously. Note : OmniPoint will automatically detect whether it should operate in current sink or current source mode Default current output settings: 1.0 mA for fault 2.0 mA for warm-up and inhibit 3.0 mA for warning 4.0 to 20.0 mA for normal gas measurement 21.0 mA for maximum over range 4 mA to 20 mA signal accuracy : ±1 % full scale |
| HART® Communication | Provides HART® communication over 1st channel of 4 mA to 20 mA output compliant with HART® 7.0 Configurable HART® communication mode: P to P mode or Multi-drop mode (up to 8 multi-drops) Functions Supported by HART® Gas reading with gas name and units of measurement 4 mA to 20 mA signal level General/device information Configuration Forcing of 4 mA to 20 mA output Detailed transmitter information (calibration and configuration status, detailed fault and warning information, fault and alarm history and etc) Detailed sensor information (supply voltage, temperature and etc) |
| Relays | Provides three fully user configurable relay outputs that are activated based on current alarm state and one fault relay that is normally energized. Provides 3 x SPDT alarm and 1 x SPDT fault relay Maximum : 240 Vac, 5A (non inductive load) Minimum 5V, 10 mA (non inductive load) |
| CERTIFICATION | |
| Hazardous Area Approvals (Transmitter/Sensor Dependent) | UL, cUL classified: UL 1203, UL 913; CSA 22.2 No. 30, CSA 22.2 No. 25, CSA 22.2 No. 60079-0, CSA 22.2 No. 60097-11 (CSA 22.2 No. 157); CSA 22.2 No. 152; Class I, Division 1, Groups A, B, C, and D; Class II, Division 1, Groups F & G IEC 60079-0, 7th Ed; IEC 60079-1, 7th Ed; IEC 60079-11 6th Ed.; IEC 60079-31, 3rd Ed.; |
| Performance Approvals (Sensor Dependent) | CSA 22.2 No. 60079-29-1 (Pending) ATEX UL 23 ATEX 2903 Rev. 0 (Pending) |
| Flammable Gas | IECEX UL 23.0011 Issue 0 (Pending) |

| WIRELESS COMMUNICATION - BLE MODULE (OPTIONAL) | |
|---|--|
| Description | The BLE module provides a wireless communication to enable the connection of OmniPoint transmitter to a smartphone or tablet. *It is easy to make BLE connection and the mobile device act as local interface of OmniPoint using the dedicated app provided by Honeywell Analytics. |
| Installation | Optional BLE module is independent of the main (display) module. The external antenna must be installed with the BLE module. |
| Mode and Version | Bluetooth point to point mode BLE 5.0 |
| Distance | Up to 66 ft (20 m) (mobile device dependant) |
| Approval | Certified and registered Bluetooth SIG. FCC, RED, IC |
| Function Supported | Gas reading with gas name and units of measurement General/device information Remote zero and span calibration Configuration Forcing of 4 mA to 20 mA output Detailed transmitter information (Instrument status, detailed fault and warning information, fault and alarm history and etc) Detailed sensor information (optical signal level, supply voltage, temperature, calibration & configuration status and etc) |
| MODBUS RTU MODULE (OPTIONAL) | |
| Description | The Modbus output module provides an isolated RS485 output to enable the connection of the OmniPoint transmitter to a multi-drop Modbus network. |
| Installation | As an optional module independent of the main (display) module, it can be additionally installed in the factory or in the field without any changing of the main (display) module. |
| Connections | RS485+, RS485-, Drain |
| Physical Layer | Isolated RS485, 2400 to 57,6K baud; 96K default |
| Address | Address range is 1 to 247; up to 32 RTUs per loop |
| Maximum # of Nodes | 247; Compatible OmniPoint transmitter only |
| Protocol | Modbus RTU |
| Function Supported | Gas reading with gas name and units of measurement General/device information Detailed transmitter information (Instrument status, detailed fault and warning information, fault and alarm history and etc) Detailed sensor information (supply voltage, temperature, calibration & configuration status and etc) |
| WIRING REQUIREMENTS | |
| Sensor | Two-wire, for XPIS Sensor module up to (984 ft) 300 m Two-wire, for XP Sensor module up to (984 ft) 300 m Refer to manual for mounting distances and wire gauge |
| GAS CONCENTRATION DISPLAY & INTERFACE | |
| Instrument | 3 inch TFT display with ring indicator, four-digit alphanumeric characters with separate units, four touch key interface |
| Remote | Local UI or BLE 5.0 enabled device via OmniPoint app |
| WARRANTY | |
| Transmitter Unit | 5 years |
| Sensor Cartridge | Sensor dependent, 1 year minimum |

6.6 HART

HART communication is provided only over 1st channel of mA output of Omnipoint.

It is possible to monitor gas reading and status and change the configuration of all three channels of OmniPoint by using one communication line because HART is a digital communication like the MODBUS RTU.

| Dynamic Variables |
|--|
| Primary Variable Sensor (ch.) 1 Gas reading |
| Secondary Variables Sensor (ch.) 2 Gas reading |
| Tertiary Variable Sensor (ch.) 3 Gas reading |

6.6.1 Local HART Module

TB1 is for power, mA outputs and HART

A load resistor is required (to create current loop)

Resister value: 250Ω

Please see the following wiring: Connect load resistor between 1-5 (mA- HART) and 1-1(V-

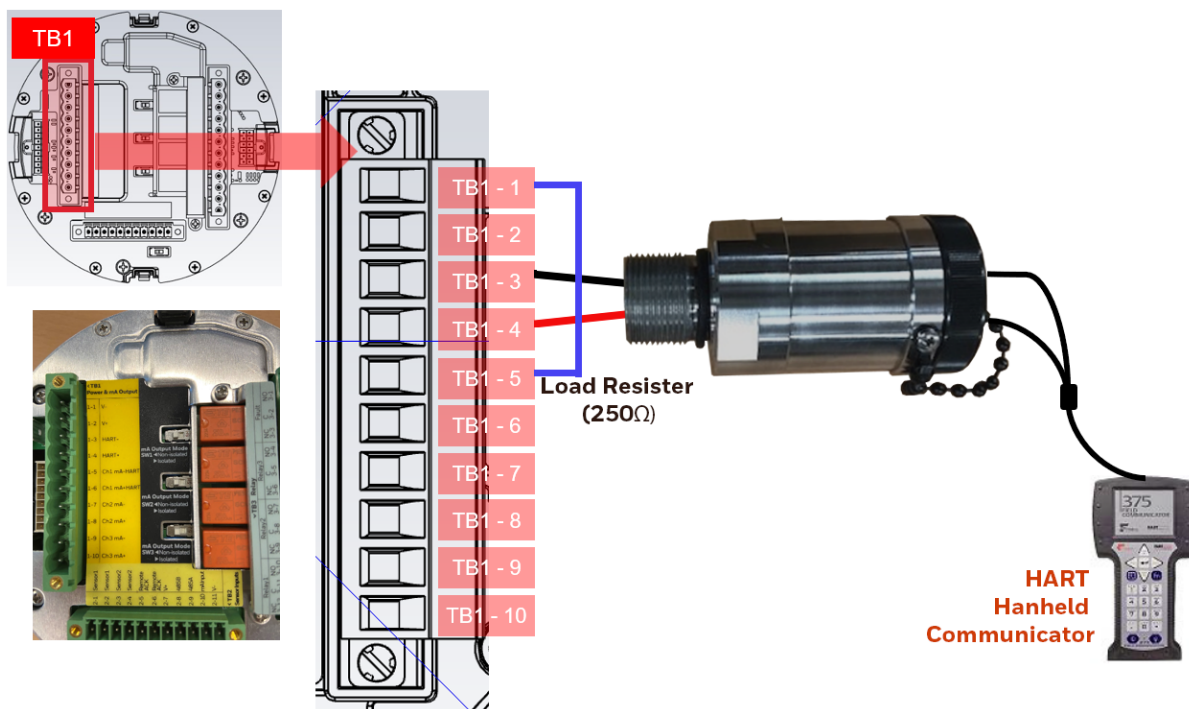

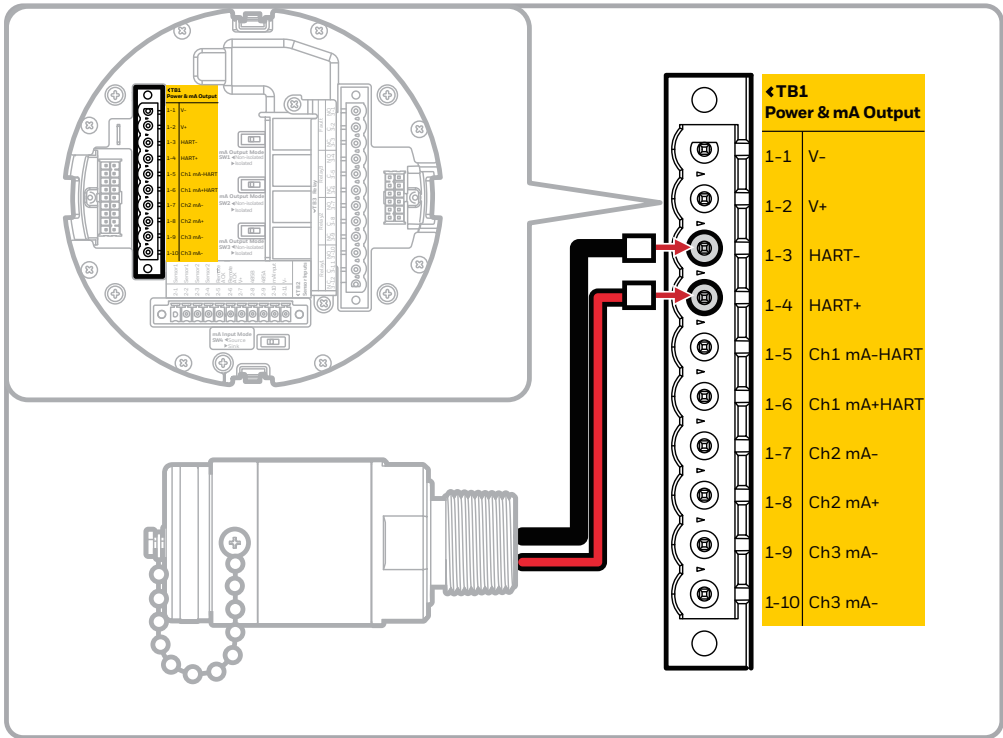

6.6.2 Device Specific Command-List

| Command | Description |
|---------|--|
| 128 | Read the latest active fault or warning string. |
| 129 | Read current transmitter state and configuration change counter |
| 130 | Read time (seconds). Seconds since December 31, 2020 |
| 131 | Set time(seconds) and date/time format. |
| 132 | Get current date/time format Get lifetime of sensors. |
| 133 | Note> It is not available for Searchpoint Optima or Searchline Excel. |
| 134 | Reset all alarms and faults. |
| 135 | Read event history (record) |
| 136 | Force / release mA loop out. |
| 137 | Read supply voltages and temperature |
| 139 | [OmniPoint Toxic Sensor Only] Set unit (ppm or mg/m3) |
| 146 | Turn on/off transmitter inhibit |
| 148 | Read 4-20mA loop current (outputs) |
| 149 | [Searchpoint Optima/Searchline Excel Only] Read beam block time and log signal level |
| 150 | [Searchpoint Optima/Searchline Excel Only] Set beam block time and log signal level |
| 151 | Send gas calibration command |
| 153 | Get alarm configuration : alarm setpoints, direction and delay time |
| 154 | Set alarm configuration: alarm setpoints, direction and delay time Read sensor types and serial number. |
| 155 | Note> S/N is not available for Searchpoint Optima. |
| 157 | Log in (change access level) |
| 158 | Read current access level (login level) |
| 159 | [Searchpoint Optima/Searchline Excel Only] Read mA loop output current settings for beam block and low signal |
| 160 | [Searchpoint Optima/Searchline Excel Only] Set mA loop output current settings for beam block and low signal |
| 161 | Read mA loop output current settings |
| 162 | Set mA loop output current settings |
| 163 | Send bump test command |
| 164 | Get relay settings |
| 165 | Set relay settings |
| 166 | Read current state of relays |
| 167 | Force / release relays |
| 168 | Get alarm, warning and fault simulation state |
| 169 | Simulate alarm, warning and fault |
| 170 | Accept new sensor |
| 171 | Get location ID |
| 172 | Set location ID |
| 173 | Get gas list(names) of a sensor channel. |
| 181 | Get MODBUS RTU configuration |
| 182 | Set MODBUS RTU configuration |
| 183 | Get allowable alarm ranges |
| 184 | Get calibration and bump test intervals and overdue warning/fault options |
| 185 | Set calibration interval and overdue warning/fault enable option Get sensor FW and data versions. |
| 188 | Note> Sensor data version is not available for Optima Plus and Excel. |
| 190 | Get option board installation status |
| 191 | Get span gas concentration of specified sensor channel. |
| 192 | Set span gas concentration of specified sensor channel. |
| 194 | Get current (target) gas names |
| 197 | Get transmitter inhibit state |
| 198 | Get RTC value as ASCII string |
| 199 | Send 4-20mA loop out calibration command Get sensor 2 & 3 additional information: unit, sensor low /upper limit, user full scale, gas reading (% of full scale) |
| 207 | Note> Sensor 1(primary) information can be read via universal command #14 |
| 208 | Get latch options of alarms and fault |
| 209 | Set latch options of alarm and fault |
| 211 | Set user full scales of specified sensor channel |
| 213 | Set bump test interval and overdue warning/fault enable option |
| 214 | Get allowable full scale range |
| 215 | Get sensor (channel) enable / disable state |
| 217 | Get transmitter serial number |

6.7 Ordering

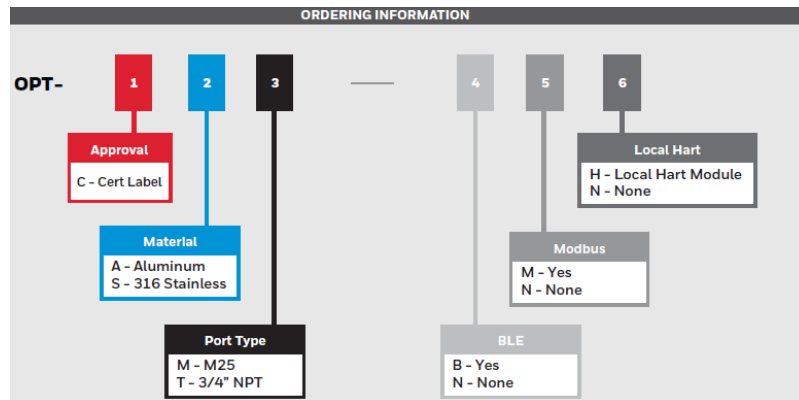

OmniPoint may be fitted with the following:

- XP (Cat bead and IR)
- XPIS (Electrochemical)
- Optima (Hydrocarbon Point IR)
- Local Hart Port

Any cable entry other than the top can be used for power or sensor connections.

OmniPoint is a gas detection system. When assessing the overall system rating, please consult the rating of each component.

- Please ensure the suitability of all components for the application.
- Please consult the rating of each component in the system and the overall suitability for the application.

Accessories



OPT-FLOW
OmniPoint Flow Housing



OPT-CAL
OmniPoint Calibration Adapter



OPT-SUN
OmniPoint Sunshield



OPT-WEATHER
OmniPoint Weatherproof Housing

OPT-PIPE – OmniPoint Pipe Mount Kit. See "Mounting the Transmitter" on page 18 for more information.

XX.1 OmniPoint - Next Generation Gas Detector

| Instrument | |
|-------------|--|
| Part Number | Description |
| OPT-CAT-NNN | OmniPoint Transmitter, Aluminum, 3/4" |
| OPT-CAM-NNN | OmniPoint Transmitter, Aluminum, M25 |
| OPT-CST-NNN | OmniPoint Transmitter, Stainless Steel, 3/4" |
| OPT-CSM-NNN | OmniPoint Transmitter, Stainless Steel, M25 |
| OPT-CAT-BNN | OmniPoint Transmitter, Aluminum, 3/4", Bluetooth |
| OPT-CAM-BNN | OmniPoint Transmitter, Aluminum, M25, Bluetooth |
| OPT-CST-BNN | OmniPoint Transmitter, Stainless Steel, 3/4", Bluetooth |
| OPT-CSM-BNN | OmniPoint Transmitter, Stainless Steel, M25, Bluetooth |
| OPT-CAT-NNH | OmniPoint Transmitter, Aluminum, 3/4", Local HART Port |
| OPT-CAM-NNH | OmniPoint Transmitter, Aluminum, M25, Local HART Port |
| OPT-CST-NNH | OmniPoint Transmitter, Stainless Steel, 3/4", Local HART Port |
| OPT-CSM-NNH | OmniPoint Transmitter, Stainless Steel, M25, Local HART Port |
| OPT-CAT-BNH | OmniPoint Transmitter, Aluminum, 3/4", Bluetooth, Local HART Port |
| OPT-CAM-BNH | OmniPoint Transmitter, Aluminum, M25, Bluetooth, Local HART Port |
| OPT-CST-BNH | OmniPoint Transmitter, Stainless Steel, 3/4", Bluetooth, Local HART Port |
| OPT-CSM-BNH | OmniPoint Transmitter, Stainless Steel, M25, Bluetooth, Local HART Port |
| OPT-CAT-BMN | OmniPoint Transmitter, Aluminum, 3/4", Bluetooth, Modbus |
| OPT-CAM-BMN | OmniPoint Transmitter, Aluminum, M25, Bluetooth, Modbus |
| OPT-CST-BMN | OmniPoint Transmitter, Stainless Steel, 3/4", Bluetooth, Modbus |
| OPT-CSM-BMN | OmniPoint Transmitter, Stainless Steel, M25, Bluetooth, Modbus |
| OPT-CAT-BMH | OmniPoint Transmitter, Aluminum, 3/4", Bluetooth, Modbus, Local HART Port |
| OPT-CAM-BMH | OmniPoint Transmitter, Aluminum, M25, Bluetooth, Modbus, Local HART Port |
| OPT-CST-BMH | OmniPoint Transmitter, Stainless Steel, 3/4", Bluetooth, Modbus, Local HART Port |
| OPT-CSM-BMH | OmniPoint Transmitter, Stainless Steel, M25, Bluetooth, Modbus, Local HART Port |
| OPT-CAT-NMN | OmniPoint Transmitter, Aluminum, 3/4", Modbus |
| OPT-CAM-NMN | OmniPoint Transmitter, Aluminum, M25, Modbus |
| OPT-CST-NMN | OmniPoint Transmitter, Stainless Steel, 3/4", Modbus |
| OPT-CSM-NMN | OmniPoint Transmitter, Stainless Steel, M25, Modbus |
| OPT-CAT-NMH | OmniPoint Transmitter, Aluminum, 3/4", Modbus, Local HART Port |
| OPT-CAM-NMH | OmniPoint Transmitter, Aluminum, M25, Modbus, Local HART Port |
| OPT-CST-NMH | OmniPoint Transmitter, Stainless Steel, 3/4", Modbus, Local HART Port |
| OPT-CSM-NMH | OmniPoint Transmitter, Stainless Steel, M25, Modbus, Local HART Port |

XX.2 OmniPoint Sensor Modules

| Sensor Modules | |
|----------------|--|
| Part Number | Description |
| OPT-S1S-T | OmniPoint Sensor Module for Toxic and Oxygen Sensor Cartridges, 3/4" NPT |
| OPT-S1S-M | OmniPoint Sensor Module for Toxic and Oxygen Sensor Cartridges, M25 |
| OPT-S1X-T | OmniPoint Sensor Module for Catalytic and IR Sensor Cartridges, 3/4" NPT |
| OPT-S1X-M | OmniPoint Sensor Module for Catalytic and IR Sensor Cartridges, M25 |
| OPT-HART-M | OmniPoint Local HART Module, 3/4" NPT |
| OPT-HART-T | OmniPoint Local HART Module, M25 |

XX.3 OmniPoint Pre-Calibrated Sensor Cartridges

| Sensor Cartridges | |
|-------------------|--|
| Part Number | Description |
| OPT-R1S-AM1 | Sensor Cartridge, NH3, 0 to 200 ppm, 50 ppm |
| OPT-R1S-AM2 | Sensor Cartridge, NH3, 0 to 1000 ppm, 200 ppm |
| OPT-R1S-CO1 | Sensor Cartridge, CO, 0 to 300 ppm, 100 ppm |
| OPT-R1S-CL1 | Sensor Cartridge, Cl2, 0 to 5.0 ppm, 1 ppm |
| OPT-R1S-HS1 | Sensor Cartridge, H2S, 0 to 15.0 ppm, 5 ppm |
| OPT-R1S-HS2 | Sensor Cartridge, H2S, 0 to 100 ppm, 20 ppm |
| OPT-R1S-OX1 | Sensor Cartridge, O2, 0 to 25% v/v, 23.5% |
| OPT-R1S-SO1 | Sensor Cartridge, SO2, 0 to 15.0 ppm, 5 ppm |
| OPT-R1X-FL1 | Sensor Cartridge, Catalytic, CH4 0 to 100 %LEL, 5% |
| OPT-R1X-FL2 | Sensor Cartridge, Catalytic, CH4 0 to 100 %LEL, 4.4% |
| OPT-R1X-ME1 | Sensor Cartridge, IR, CH4 0 to 100 %LEL, 5% |
| OPT-R1X-ME2 | Sensor Cartridge, IR, CH4 0 to 100 %LEL, 4.4% |
| OPT-R1X-PR1 | Sensor Cartridge, IR, C3H8 0 to 100 %LEL, 2.1% |
| OPT-R1X-PR2 | Sensor Cartridge, IR, C3H8 0 to 100 %LEL, 1.7% |

XX.4 OmniPoint Accessories

| Accessories | |
|--------------|--|
| Part Number | Description |
| OPT-PIPE | OmniPoint Pipe Mount Kit |
| OPT-FLOW | OmniPoint Flow Housing |
| OPT-CAL | OmniPoint Calibration Adapter |
| OPT-SUN | OmniPoint Sunshield |
| OPT-WEATHER | OmniPoint Weatherproof Housing |
| 2430-0021 | UL/CSA Aluminum 3-Wire Junction Box (for OmniPoint Sensor Modules) |
| 2441-0022 | UL/CSA Aluminum 6-Wire Junction Box (for Searchpoint Optima Plus) |
| 00780-A-0100 | ATEX/IECEx Ex e Junction Box |

7.1 Install the OmniPoint App

1. Android only – Go to the *Android Play store* and install the OmniPoint app on your Smartphone.
2. Login or Sign Up with the User/Password provided by the Installation Team.

7.2 Sign Up

First-time procedure to create your account.

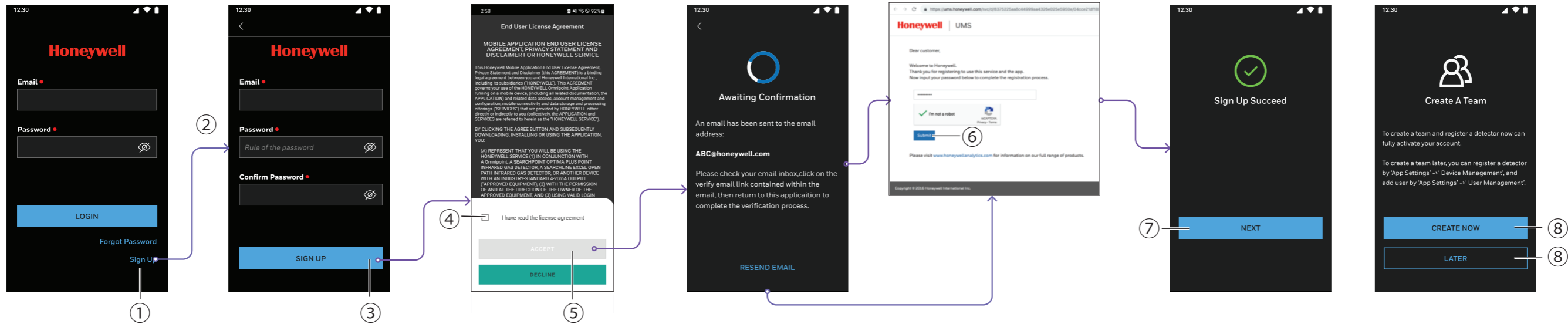

1. Tap **Sign Up**.
2. Enter an **Email** and new **Password**.
3. Tap **Sign Up**.
4. Check the **End User License Agreement** box.
5. Tap **Accept** and wait for an email with further instructions.
6. Click the verifying email link and go to the mobile app to complete the signup process.
7. Tap See "Register a Device & Company" on the facing page for more information. or **Later** to Connect a device.

7.3 Register a Device & Company

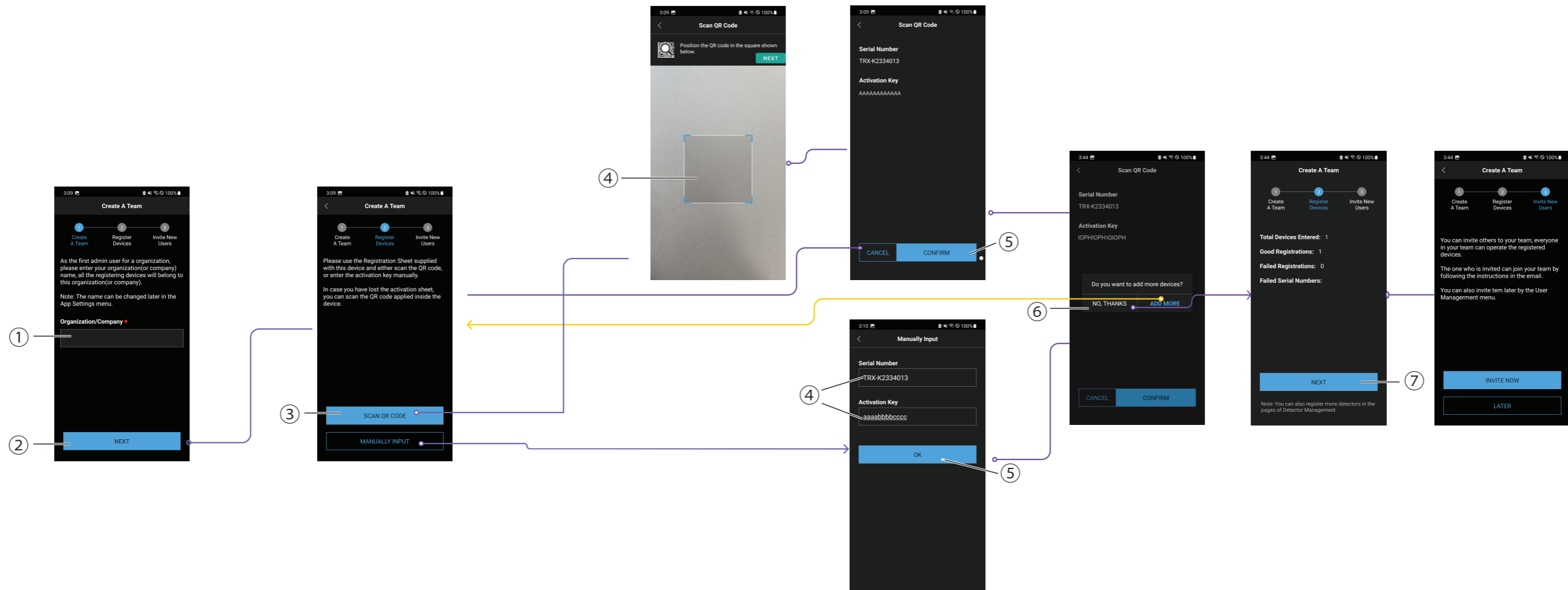

1. Enter your **Organization's name**.
2. Tap **NEXT**.
3. Tap **Scan QR Code**.
4. Scan the QR Code included in the packaging and the Transmitter.
 - a. Optional Step: Tap **Manually Input** if you don't have a QR Code and enter the Serial number and Activation key.
5. Tap **Confirm / Ok**.
6. Tap **No, Thanks** to the *Do you want to add more devices?* Question.
7. Tap **Next** to complete the registration process.
 - a. Optional Step: Tap **Next** to Invite New Users

7.4 Bluetooth Pairing

1. Turn on the Bluetooth on your Smartphone, select your detector and tap **Connect**.

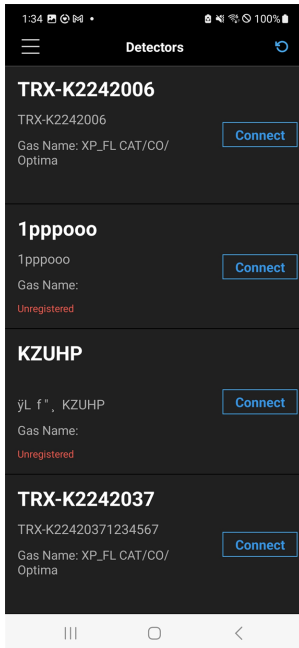

2. Pair your Smartphone with the transmitter via Bluetooth following onscreen instructions.

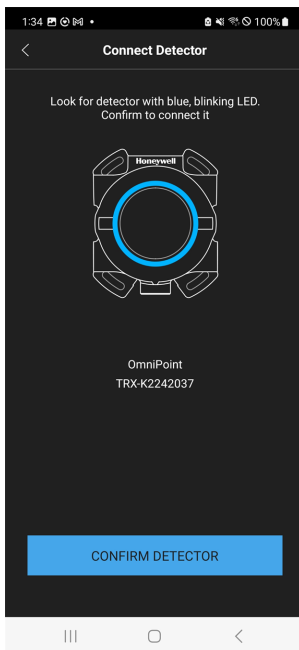

Note: You can only connect your smartphone with one transmitter at a time.

7.5 Mobile App Menu Navigation

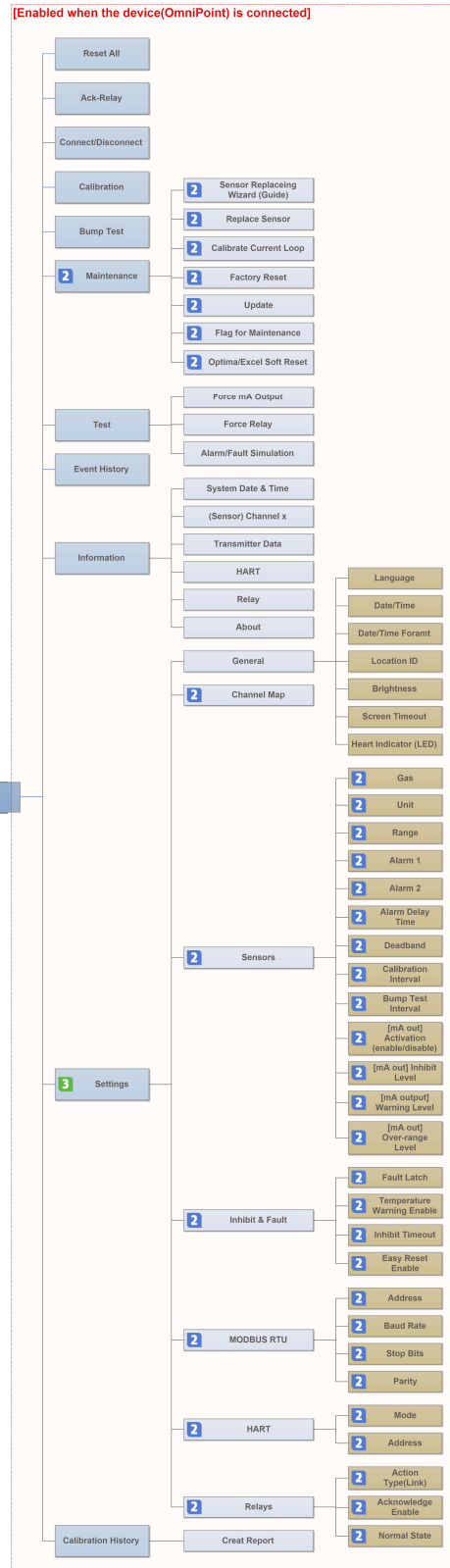
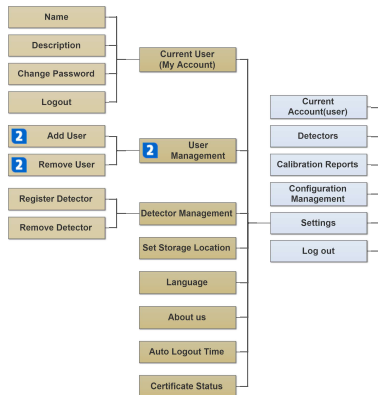
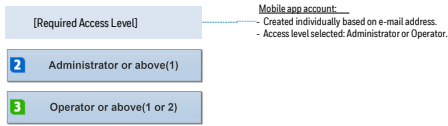

7.6 Bluetooth Hardware and Wiring

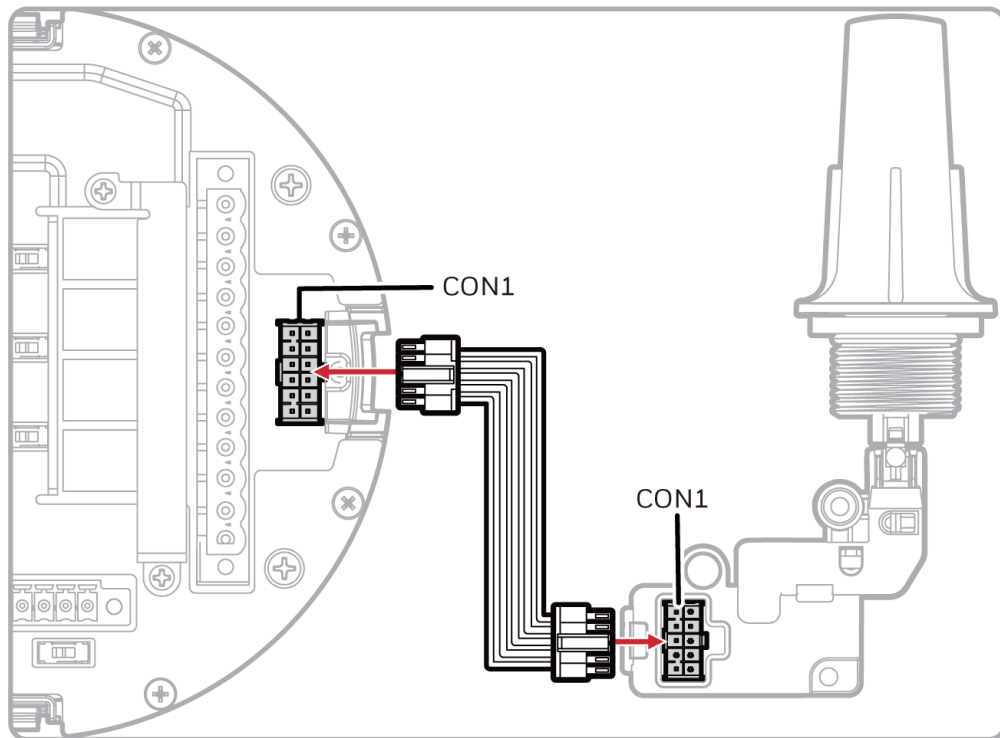
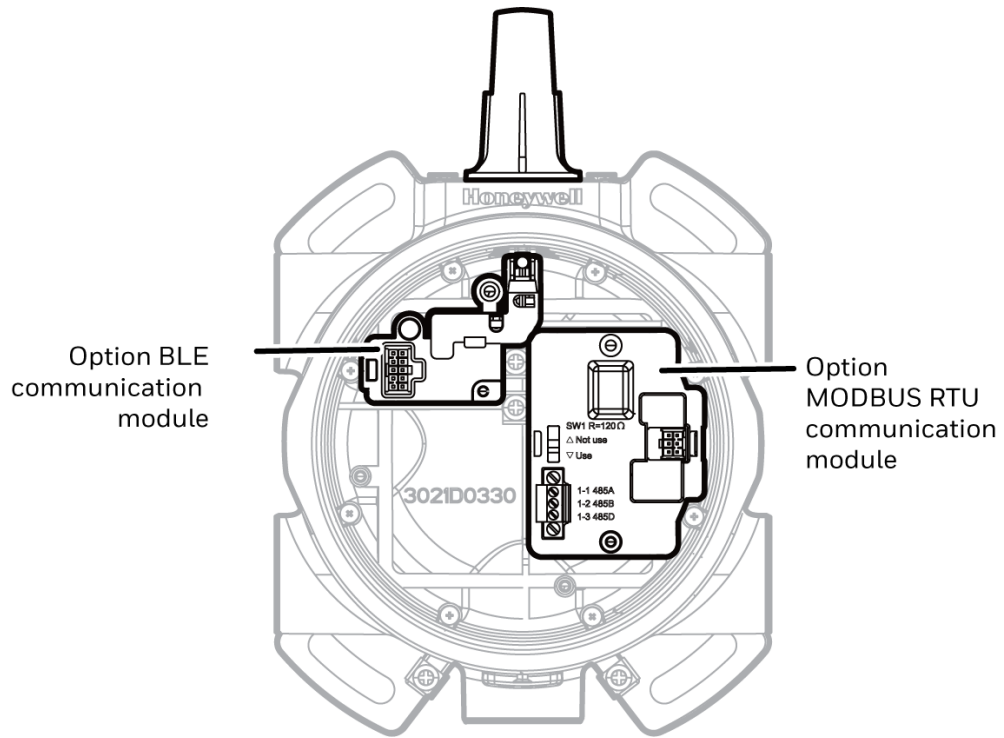

7.7 Security Guide

Honeywell recommends that customers with affected products should take the following steps to protect themselves:

- Update the firmware of vulnerable instruments as per the security notification.
- Isolate their system from the Internet or create additional layers of defense to their system from the Internet by placing the affected hardware behind a firewall or into a DMZ.
- If remote connections to the network are required, please consider using a VPN or other means to ensure secure remote connections into the network device are on.
- Keep the “Registration sheet”, “QR-Code”, and “Activation-key” of the device safe to prevent unauthorized access.
- Allow only trained and trusted people to connect to your device.
- Not recommend using 3rd party keyboard. Using a Mobile app through a 3rd party keyboard can result in malicious information leakage.
- Recommends setting passwords according to the following guides (rules).
 - Using (setting) a strong password that combines numbers, characters, and special characters.
 - Do not use the same character in succession.
 - Avoid using passwords that were used in the past.
 - The password must be changed within 90 days.
 - Prohibit consecutive numbers, letters, and easy-to-guess passwords such as birthday and phone numbers.
 - Do not use easy words or names in the dictionary as passwords.

7.8 Contact Us

Europe, Middle East, Africa:

Life Safety Distribution GmbH

Javastrasse 2

8604 Hegnau

Switzerland

Tel: +41 (0)44 943 4300

gasdetection@honeywell.com

Americas:

Honeywell Analytics Distribution Inc.

405 Barclay Blvd.

Lincolnshire, IL 60069

USA

Tel: +1 847 955 8200

Toll-free: +1 800 538 0363

detectgas@honeywell.com

Technical Services

EMEA: gastechsupportemea@honeywell.com

Americas: is.gas.techsupport@honeywell.com

AP: gas.techsupport.apaci@honeywell.com

LATAM: SoporteTecnico.HGAS@honeywell.com



Scan this code for further reference to the OmniPoint on the Honeywell website

User Manual3021M5000

Language: English

Revision A

12/19/2024

@ 2024 Honeywell International INC.

automation.honeywell.com