

# V4055A,B,D,E On-Off Fluid Power Gas Valve Actuator

## PRODUCT DATA



## APPLICATION

The V4055 Gas Valve Actuator, in combination with a VE5000<sup>a</sup>, V5055 or V5097 Gas Valve, controls the gas supply to commercial and industrial burners.

When replacing a V4034 with a V4055, the V5034 gas valve must also be replaced with a V5055 or V5097 gas valve.

## FEATURES

- The V4055 Actuator, when used with the VE5000<sup>a</sup>, V5097 or V5055 Valve, is rated for final safety shutoff service.
- The V4055 Actuator can be used with the characterized guide model of the V5055 or V5097 Gas Valve to enhance lightoff smoothness.

**NOTICE:** Per Industry Standards, the actuator is required a conduit seal or a cable type that is sealed be installed in a device that can result in a flammable liquid flow through a conduit or cable to an electrical ignition source in the event of a seal leakage or diaphragm failure.

- The standard model has an opening time of 26 seconds at 60 Hz or 32 seconds at 50 Hz. A fast-opening model is available with timings of 13 seconds at 60 Hz or 16 seconds at 50 Hz.
- Maximum closing time is one second, which meets code, standard and insurer requirements.
- Models available with damper shaft, with or without spring return; shaft extends out both sides and rides in Teflon-like Delrin bushings; used with standard 7616BR Damper Crank Arm.
- Red OPEN indicator attached to actuator stem shows when valve is even slightly open; yellow SHUT indicator on valve stem shows only when gas valve is fully closed.
- Models available with adjustable max flow limit switch.
- Ambient temperature rating is -40°F to +150°F (-40°C to +66°C) for 60 Hz models and -10°F to +158°F (-23°C to +70°C) for 50 Hz and 50/60 Hz models.
- Valve and actuator combinations can be mounted in any position, with the exception of the 220 to 240 Vac, 50/60 Hz models, which are mounted vertically.
- Models available with factory-installed single pole double throw (spdt) field-adjustable Auxiliary Switch. Field-addable Auxiliary Switch kits are also available.
- Standard enclosure meets NEMA 1 (IP30) requirements; models available with NEMA 4 (IP54) weatherproof enclosure.
- V4055D and high pressure V4055E with Proof-of-Closure Switch and V5055/V5097C or E with valve seal overtravel interlock (double seal) to meet specific code, standard and insurer requirements.

<sup>a</sup> VE5000 is a European manufactured and approved valve for European use only.

## Contents

Application .....	1
Features .....	1
Specifications .....	2
Ordering Information .....	2
Installation .....	4
Wiring .....	6
Checkout and Service .....	7



# SPECIFICATIONS

**Models:**

V4055A Actuator, with V5055, V5097 or VE5000 Gas Valves, provides on-off control of fuel. With proper adapter (see Accessories), it replaces the V4034 Actuator on a V5034 Gas Valve.

V4055B Actuator is a high pressure version of V4055A.

V4055D Actuator is identical to V4055A, except has a Proof-of-Closure Switch. Used with V5055C/V5097C (double seal) for valve seal overtravel interlock.

V4055E Actuator is identical to V4055B, except has a Proof-of-Closure Switch. Used with V5055E/V5097E (double seal) for valve seal overtravel interlock.

NEMA 4 weatherproof models available.

**Nominal Opening Time:** See Table 1.

**Table 1. Nominal Opening Time (seconds).**

Model	50 Hz	60 Hz
Standard	32	26
Fast-opening	16	13

**Maximum Closing Time:** One second when de-energized.

**Ambient Operating Temperature Ratings:**

60 Hz Models: -40°F to +150°F (-40°C to +66°C).

50 Hz, 50/60 Hz Models: -10°F to +158°F (-23°C to +70°C).

**Mounting:** V4055 Actuator attaches directly to V5055/V5097

Valve with two sets of screws positioned 90 degrees apart.

Combination is multipoise.

**NOTE:** 220 to 240 Vac, 50/60 Hz models are vertical mount only.

**Pressure Ratings:** See Table 2.

**Table 2. Pressure Ratings of Valve-Actuator Combinations.**

Model	Pipe Size	STANDARD PRESSURE ACTUATORS V4055A, D, F, G				HIGH PRESSURE ACTUATORS V4055B, E			
		M.O.P.D. <sup>a</sup>		Max. Rated Pressure <sup>b</sup>		M.O.P.D. <sup>a</sup>		Max. Rated Pressure <sup>b</sup>	
STANDARD PRESSURE VALVES V5055A, B, C, F, V5097A, B, C	3/4" to 1-1/2" <sup>c</sup>	5 PSI	340 mbar	15 PSI	1.0 Bar	15 PSI	1030 mbar	15 PSI	1.0 Bar
	2" to 3" <sup>d</sup>	5 PSI	340 mbar	15 PSI	1.0 Bar	15 PSI	1030 mbar	15 PSI	1.0 Bar
	4" flanged <sup>e</sup>	3 PSI	207 mbar	15 PSI	1.0 Bar	5 PSI	340 mbar	15 PSI	1.0 Bar
HIGH PRESSURE VALVES V5055D, E, V5097D, E	3/4" to 1-1/2" <sup>c</sup>	5 PSI	340 mbar	75 PSI	5.0 Bar	25 PSI	1720 mbar	75 PSI	5.0 Bar
	2" to 3" <sup>d</sup>	5 PSI	340 mbar	45 PSI	3.0 Bar	15 PSI	1030 mbar	45 PSI	3.0 Bar

<sup>a</sup> Max Operating Pressure Differential (UL) or Max Operating Pressure (CSA): maximum allowable pressure drop from inlet to outlet for proper operation.

<sup>b</sup> Max rated pressure (UL) or Max Close-off Pressure (CSA): maximum (UL) pressure that the valve can be exposed to without leakage or damage to the valve.

<sup>c</sup> Applies for small-body V5097 valves 3/4" up to 2" pipe size.

<sup>d</sup> Applies for large-body V5097 valves 2" up to 3" pipe size.

<sup>e</sup> V5055A, B, C only.

**Electrical Ratings:** See Tables 3 and 4.

# ORDERING INFORMATION

When purchasing replacement and modernization products from your TRADELINE® wholesaler or distributor, refer to the TRADELINE® Catalog or price sheets for complete ordering number. If you have additional questions, need further information, or would like to comment on our products or services, please write or phone:

1. Your local Honeywell Environmental and Combustion Controls Sales Office (check white pages of your phone directory).
2. Honeywell Customer Care  
1885 Douglas Drive North  
Minneapolis, Minnesota 55422-4386
3. <http://customer.honeywell.com> or <http://customer.honeywell.ca>

International Sales and Service Offices in all principal cities of the world. Manufacturing in Belgium, Canada, China, Czech Republic, Germany, Hungary, Italy, Mexico, Netherlands, United Kingdom, and United States.

Table 3. V4055A,D Electrical Ratings.

Voltage and Frequency	Opening (Standard)				Opening (Fast)				Holding		
	Inrush	(W)	(A)	(VA)	Inrush	(W)	(A)	(VA)	(W)	(A)	(VA)
100/50-60 <sup>a</sup>	—	43.0	0.91	91	—	58.0	1.30	130	10.4	0.16	16
100/50-60 <sup>b</sup>	—	33.0	0.6	67	—	43.0	0.91	91	8.4	0.14	14
120/60	3.9	50.0	0.94	115	5.4	71.0	1.33	160	9.5	0.12	14
200/50-60 <sup>a</sup>	—	68.0	0.79	158	—	88.0	1.10	220	10.6	0.09	18
200/50-60 <sup>b</sup>	—	48.0	0.52	104	—	63.0	0.72	144	9.0	0.07	14
220/50	1.6	55.5	0.55	121	3.0	76.0	0.80	176	9.0	0.06	14
240/50	—	81.5	0.79	190	—	95.0	1.00	240	9.1	0.06	14
240/60	2.6	51.0	0.45	115	4.0	71.5	0.68	160	9.2	0.06	14
220-240/50-60 <sup>c</sup>	—	—	—	—	—	70.3	0.59	136	7.2	0.07	16
220-240/50-60 <sup>d</sup>	—	—	—	—	—	58.6	0.46	106	5.9	0.06	14

<sup>a</sup> 50 Hz power supply.

<sup>b</sup> 60 Hz power supply.

<sup>c</sup> 230 Vac, 50 Hz power supply.

<sup>d</sup> 230 Vac, 60 Hz power supply.

Table 4. V4055B,E Electrical Ratings.

Voltage and Frequency	Opening (Standard)				Opening (Fast)				Holding		
	Inrush	(W)	(A)	(VA)	Inrush	(W)	(A)	(VA)	(W)	(A)	(VA)
120/60	—	60	0.94	115	—	60.0	0.94	115	9.5	0.16	19
220-240/50-60 <sup>a</sup>	—	—	—	—	—	68.9	0.58	133	6.7	0.08	18
220-240/50-60 <sup>b</sup>	—	—	—	—	—	58.2	0.46	106	5.3	0.06	14

<sup>a</sup> 230 Vac, 50 Hz power supply.

<sup>b</sup> 230 Vac, 60 Hz power supply.

**Auxiliary Switch and Proof-of-Closure Switch Ratings:** See Table 5.

Table 5. Auxiliary Switch and Proof-of-Closure Switch Ratings (1/2 hp [0.37kW]<sup>a</sup>).

Load	120V	240V
Full Load	9.8A	4.9A
Locked Rotor	58.8A	29.4A

<sup>a</sup>Maximum total connected power to both switches (if used) is 1800 VA.

**Mounting Dimensions:** See Fig. 1 and Table 7.

**Damper Shaft:** Shaft is 3/8 in. (9.5 mm) square, for use with 7616BR Damper Crank Arm (ordered separately) and with or without damper shaft return spring.

**Maximum Damper Shaft Rotation:** 52 angular degrees.

**Maximum Force:** 2-11/16 in. (68.3 mm) radius for 7616BR Damper Crank Arm ordered separately (see Accessories section).

**NOTE:** Damper shaft drives damper crank arm in one direction only; optional return spring is available on damper shaft to turn damper crank arm in opposite direction. See Table 6.

Table 6. Actuator Torque (With and Without Return Spring).

V4055 Model	-40°F to +20°F (-40°C to -7°C)		20°F to 150°F (-7°C to +66°C)	
	lb	N	lb	N
With return spring	5	22.2	10	44.5
Without return spring	5	22.2	20	89.0

**Approvals:**

Underwriters Laboratories Inc. Listed: File No. MH1639, Guide No. YIOZ.

Factory Mutual: Listed.

Canadian Standards Association certified: General Listed file numbers 158158 Class 3371

For U.S.A. and Canada: certified 60 Hz models only.

Swiss Re (Formerly GeGap/IRI) Acceptable.

Some V4055 Actuators are approved as Class A valves in accordance with EN161:

When used with V5055 Valves: Pin: CE-0063AR1359.

When used with VE5000 Series Valves: Pin: CE-0063AP3075.

V4055A,B,D,E ON-OFF FLUID POWER GAS VALVE ACTUATOR

**Accessories:**

- 133568 Auxiliary Switch Bag Assembly (not for models with maximum flow limit switch).
- 133569 Valve-Closed Indication Switch Bag Assembly.

**NOTE:** Check local codes for acceptance of adding the switch and using the valve seal overtravel V5055C or V5055E valves.

7616BR Damper Crank Arm (damper arm and clip).

**Available Models:** V4055 with NEMA 4 enclosure (weatherproof).

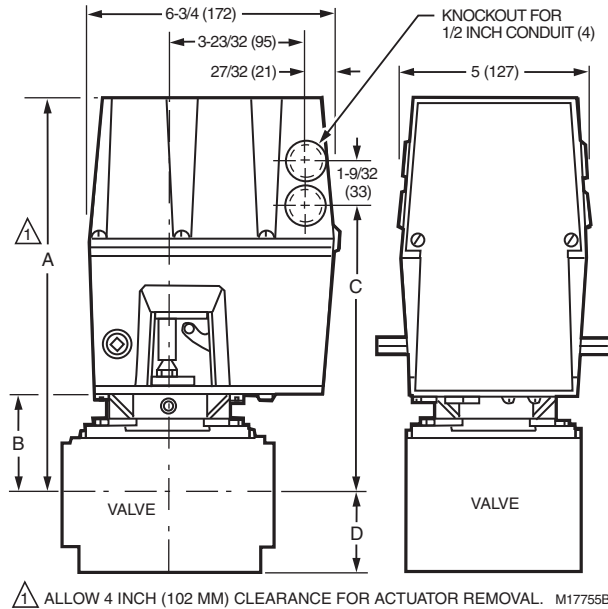

**Fig. 1. Approximate mounting dimensions of V4055 Actuators in in. (mm).**

**Table 7. Approximate Mounting Dimensions of V4055 Actuators with V5055 and V5097 Valves.**

Valve Size <sup>a</sup> (in.)	V5055								V5097								
	Dim. A		Dim. B		Dim. C		Dim. D		Dim. A		Dim. B		Dim. C		Dim. D		
	in.	mm	in.	mm	in.	mm	in.	mm	in.	mm	in.	mm	in.	mm	in.	mm	
Small Body	3/4	11-1/8	283	2-3/4	70	8-3/16	208	5-3/4	146	11-1/8	283	2-3/4	70	8-3/16	208	2-1/2	64
	1	11-1/8	283	2-3/4	70	8-3/16	208	5-3/4	146	11-1/8	283	2-3/4	70	8-3/16	208	2-1/2	64
	1-1/4	11-1/8	283	2-3/4	70	8-3/16	208	5-3/4	146	11-1/8	283	2-3/4	70	8-3/16	208	2-1/2	64
	1-1/2	11-1/8	283	2-3/4	70	8-3/16	208	5-3/4	146	11-1/8	283	2-3/4	70	8-3/16	208	2-1/2	64
	2	11-1/8	286	2-7/8	73	8-5/16	211	8-3/8	213	11-3/4	298	3-3/8	86	8-3/8	213	4	102
Large Body	2	11-3/4	298	3-3/8	86	8-13/16	224	9-1/4	235	11-3/4	298	3-3/8	86	8-3/8	213	4	102
	2-1/2	11-3/4	298	3-3/8	86	8-13/16	224	9-1/4	235	11-3/4	298	3-3/8	86	8-3/8	213	4	102
	3	11-3/4	298	3-3/8	86	8-13/16	224	9-1/4	235	11-3/4	298	3-3/8	86	8-3/8	213	4	102
	4	14-1/8	359	5-13/16	148	11-7/32	285	12-1/2	318	—	—	—	—	—	—	—	—

<sup>a</sup> Valve size using accessory pipe adapter fitting.

# INSTALLATION

## When Installing This Product...

1. Read these instructions carefully. Failure to follow them could damage the product or cause a hazardous condition.
2. Check the ratings given in the instructions and on the product to make sure the product is suitable for your

3. Installer must be a trained, experienced flame safeguard control technician.
4. After installation is complete, check out product operation as provided in these instructions.

## **!** WARNING

### Electrical Shock Hazard.

### Can cause serious injury or death.

Disconnect power supply before making wiring connections to prevent electrical shock and equipment damage.

#### IMPORTANT:

1. All wiring must comply with all applicable electrical codes, ordinances, and regulations. All wiring must be NEC Class 1.
2. Voltage and frequency of the power supply connected to this control must agree with those marked on the device.
3. Loads connected to the Auxiliary Switch and/or Proof-of-Closure Switch, if used, must not exceed the ratings given in the Specifications section.

**NOTICE:** Per Industry Standards, the actuator is required a conduit seal or a cable type that is sealed be installed in a device that can result in a flammable liquid flow through a conduit or cable to an electrical ignition source in the event of a seal leakage or diaphragm failure.

## Install Valve

The actuator is mounted directly on the valve bonnet after the valve is installed in the gas supply line. Refer to the instructions packed with the gas valve for installation details. When installing the gas valve, make sure:

1. Sufficient clearance is left to install and service the actuator.
2. Ambient temperatures at the valve location do not exceed actuator ratings. See Specifications section.
3. Position of the valve permits hookup to the damper if one is controlled.

## Install Accessory Switches (If Needed)

An spdt switch can be installed to operate an auxiliary load up to 1/2 hp (0.37 kW). See Table 5. The switch can be adjusted to operate at any point in the valve stroke.

A Proof-of-Closure Switch can also be installed with a V5055/V5097C or E Valve (with double seal) on any V4055 Actuator to provide a valve seal overtravel interlock. The Proof-of-Closure Switch is installed to make or break a circuit when the valve is in the closed position. The switch is not adjustable.

**NOTE:** Mark the actuator or valve to indicate any changes made.

To install the switches:

1. Remove the actuator faceplate (two screws).
2. Remove the silver-colored barrier to expose the actuator stem.
3. Insert the Auxiliary Switch in the position indicated in Fig. 2. Fasten with two screws through the actuator base.
4. Insert the Proof-of-Closure Switch in the position shown in Fig. 2. The switch mounts against the side of the actuator housing. The mounting holes are spaced to assure

mounting the switch in the correct position. Fasten with two screws through the actuator base. (The Proof-of-Closure Switch is not adjustable.)

5. If only one switch is used, install the narrow barrier included with the switch in the unused space.
6. Mount the actuator before making wiring connections and adjustments to the Auxiliary Switch.

## Mount Actuator on Valve

1. Check the final position of the valve body to be sure that the actuator is in the proper position when mounted on the valve. This is especially important when the actuator is used to drive a damper.
2. If two smaller sized valves are mounted very closely together, as in an Industrial Risk Insurers approved type of valve train, it may be necessary to mount the actuators off center to provide adequate clearance.

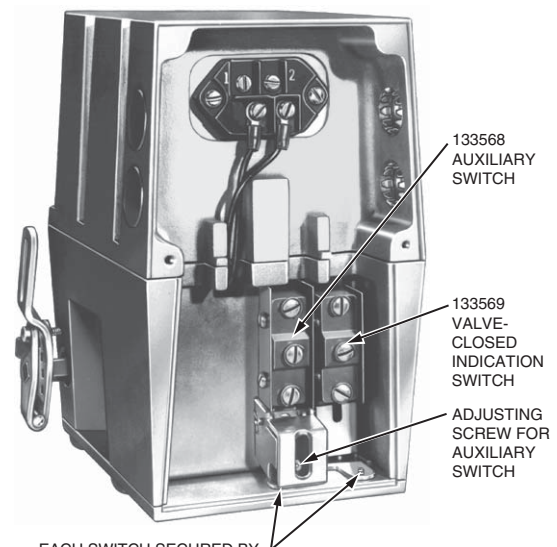

EACH SWITCH SECURED BY TWO SCREWS FROM UNDERSIDE OF BASE.  
IF ONLY ONE SWITCH IS USED, INSTALL BARRIER IN OPEN POSITION.

M7326C

**Fig. 2. V4055 Actuator with cover removed.**

3. Slip the bottom collar of the actuator over the valve bonnet assembly. Rotate the actuator to the desired position and use a 5/32 in. Allen wrench to securely tighten the two setscrews to 50 to 60 lb-in. (5.7 to 6.8 N•m).
4. Connect the damper linkage, if used. Refer to the instructions packed with the damper arm.

## Mount and Adjust 7616BR Damper Crank Arm (If Used)

#### IMPORTANT:

*When a damper crank arm is used with a NEMA 4 actuator that is exposed to ice or sleet, a suitable shield must be installed to prevent ice or sleet buildup.*

Follow installation and adjustment directions included with damper crank arm. Maximum push rod travel is 2-5/16 in. (59 mm) through a stroke of 52 degrees. See Fig. 3.

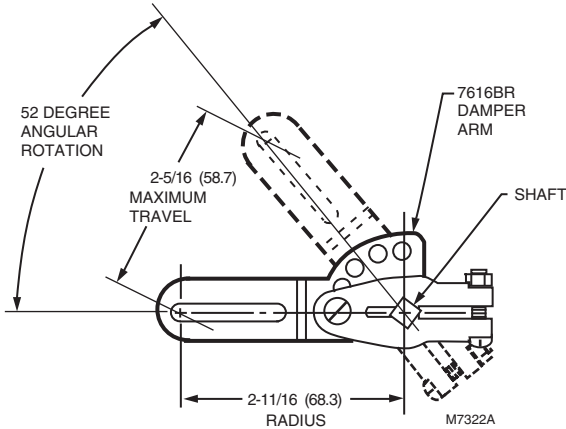

Fig. 3. 7616BR Damper Crank Arm can be attached to actuator shaft to drive a damper when valve is open.

## WIRING

### WARNING

**Electrical Shock Hazard.**

**Can cause serious injury or death.**

Disconnect power supply before making wiring connections to prevent electrical shock and equipment damage.

**NOTICE: Per Industry Standards, the actuator is required a conduit seal or a cable type that is sealed be installed in a device that can result in a flammable liquid flow through a conduit or cable to an electrical ignition source in the event of a seal leakage or diaphragm failure.**

Wiring must comply with all applicable electrical codes, ordinances and regulations. Wiring to the actuator must be NEC Class 1.

Connect the power supply to terminals 1 and 2 on the V4055 terminal strip. Refer to Fig. 4 for Auxiliary Switch connections and Fig. 5 for Max Flow Limit Switch connections. For typical system hookups, refer to instructions packed with the device used to control the valve.

When all wiring connections are complete, replace the actuator faceplate.

### CAUTION



**Operation Hazard.**

**Improper wiring can cause improper and dangerous operation.**

Label all wires prior to disconnection when servicing valves. Wiring errors can cause improper and dangerous operation.

**NOTE: Pipe sealant is required on the conduit threads of actuators with NEMA 4 enclosures.**

## Adjust Auxiliary Switch (If Used)

The Auxiliary Switch is adjustable throughout the stroke of the actuator. With the switch installed in the actuator, turn the adjusting screw (see Fig. 2) clockwise  to cause the switch to operate earlier in the stroke or counter-clockwise  to cause the switch to operate later in the stroke.

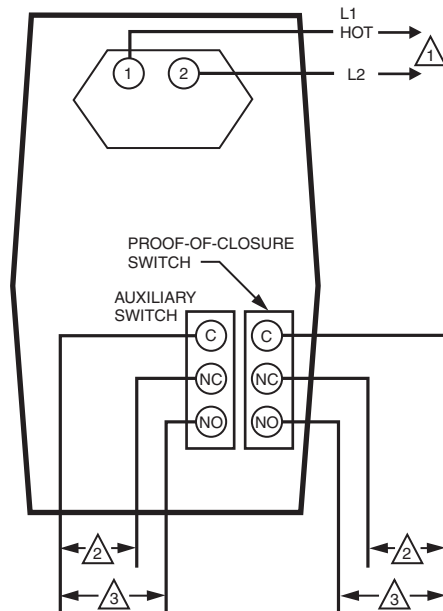

 POWER SUPPLY. PROVIDE OVERLOAD PROTECTION AND DISCONNECT MEANS AS REQUIRED.

 SWITCH BETWEEN THESE TWO LEADS IS CLOSED WHEN VALVE IS SHUT (DE-ENERGIZED).

 SWITCH BETWEEN THESE TWO LEADS IS OPEN WHEN VALVE IS SHUT (DE-ENERGIZED).

M7334B

Fig. 4. External connections to the V4055 Actuator.

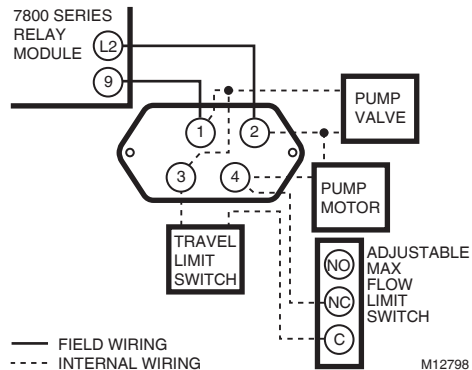



Fig. 5. Connecting the Max Flow Limit Switch to the actuator.

**NOTE: The Proof-of-Closure Switch is not adjustable.**

## Adjust Max Flow Limit Switch (If Used)

The Max Flow Limit Switch is adjustable throughout the stroke of the actuator. With the switch installed in the actuator, turn the adjusting screw clockwise  to cause the switch to operate earlier in the stroke or counter-clockwise  to cause the switch to operate later in the stroke.

## CHECKOUT AND SERVICE



### CAUTION

**Equipment Damage Hazard.**

**Unskilled technicians can cause equipment damage.**

Only a trained, experienced, flame safeguard technician should check out and service this control.

### Checkout

After the installation is complete, cycle the valve several times with the manual fuel shutoff cock closed before testing the system in actual operation.

### Service

The actuator is not field repairable except for replacing the Auxiliary Switch, Max Flow Limit Switch or Proof-of-Closure Switch. See Installation section for procedure. Do not disassemble the valve actuator.

If the actuator fails to operate properly, replace it.

1. Turn off the gas supply at the manual shutoff valve located upstream from the valve(s) being serviced.
2. Shut off all electrical power to the valve actuator(s).
3. Mark and disconnect the wires from the actuator terminals. Remove conduit and disengage the damper linkage assembly (if applicable).
4. Loosen the two set screws from the valve to lift off the actuator.
5. If the actuator is to be replaced and it did not leak hydraulic fluid, skip to Step 11.

**NOTE:** It is good practice to inspect the inside of the valve whenever the actuator is replaced. To do so, remove the bonnet assembly, inspect the valve and bonnet. If all is well, proceed to Step 7.

6. If the actuator leaked hydraulic fluid onto the valve (the fluid is red), it must be cleaned off from the valve and bonnet assembly.
  - a. Wipe off the outer valve body.
  - b. Remove the valve bonnet bolts and lift off the bonnet.

**NOTE:** V5055/V5097C and E Valves have additional internal springs that will push the bonnet up as the bolts are loosened.

- c. Inspect the inside of the valve.

### IMPORTANT:

*If fluid is present on the inside surfaces of the valve body or bonnet surfaces, the bonnet assembly or entire valve must be replaced. See Table 8 below for the bonnet assembly part number.*

- d. If the inside surfaces are clear of hydraulic fluid, clean the bonnet assembly and be sure to remove all hydraulic fluid from the inside and outside of the actuator mounting curb. This is the “cup-like” area around the valve stem. Avoid using a cleaning solution as it may damage the rubber seals used in the valve.
7. If the valve bonnet assembly is in good condition and is not replaced, replace the bonnet seal. Do not reuse the old bonnet seal. See Table 9 below for the seal number.
8. Coat seals with grease provided and position in valve body/bonnet assembly.
9. Carefully seat the bonnet assembly on the valve body. Be sure the seals are in their proper position. On those valves with a spring below the disc, be sure the spring is centered in the indentation on the inside of the valve body.
10. After positioning the bonnet assembly, replace the screws removed earlier.

**NOTE:** When replacing the bonnet assembly on the 4-inch valve, draw it evenly into the valve body. Finger-tighten the eight bolts. Draw the bonnet assembly into the valve by tightening, in order, bolts 1, 5, 7 and 3 (two turns each). Repeat until the bonnet assembly is seated. Tighten the remaining bolts. Torque the bolts as follows:

Valve Size	Torque
3/4 in. (19 mm) to 1-1/2 in. (38 mm)	55 in.-lb.
2 in. (51 mm) to 4 in. (102 mm)	75 in.-lb.

11. Remount the actuator on the bonnet assembly. Tighten the two set screws (50-60 inch pounds).
12. Replace the damper crank arm assembly.
13. Re-attach the wires removed from the actuator terminals and turn on the electrical power.
14. With the gas still off, cycle the actuator to check for proper mechanical operation.



### CAUTION

**Be sure to perform a bonnet seal and seat leak check after installation.**

Be sure to read and follow all instructions that come with the actuators, valves, seal and bonnet kits.

**Table 8. Replacement Bonnets for V5055/V5097 Gas Valves.**

Replacement Bonnet**	Valve		Valve Size (in in.)
133398AA	V5055A	V5097A	3/4, 1, 1-1/4, 1-1/2
133417AA			2, 2-1/2, 3
Not available		(On-Off)	4
133398BA	V5055B	V5097B	3/4, 1, 1-1/4, 1-1/2
133417BA			2, 2-1/2, 3
Not available		(Characterized Guide)	4
133398CA	V5055C	V5097C	3/4, 1, 1-1/4, 1-1/2
133417CA			2, 2-1/2, 3
136911CA		(Proof of Closure)	4
Not available	V5055D	V5097D	3/4, 1, 1-1/4, 1-1/2
Not available			2, 2-1/2, 3
136308BA	V5055E	V5097E	3/4, 1, 1-1/4, 1-1/2
Not available			2, 2-1/2, 3

**Table 9. Gas Valve Replacement Seals.**

Replacement Seal Assy #	Valve Size (in in.)
133393A	3/4, 1, 1-1/4, 1-1/2
133392A	2, 2-1/2, 3
137253A	4

**\*\*Each replacement assembly contains the bonnet assembly, two rubber seals, and a tube of grease. It must be used only on the type of valve indicated above.**

**Automation and Control Solutions**

Honeywell International Inc.  
 1985 Douglas Drive North  
 Golden Valley, MN 55422  
 customer.honeywell.com

