

**Table of Contents**

Table of Contents ..... Page 1  
 Approvals ..... Page 1  
 Attention ..... Page 1  
 Specification ..... Page 2  
 Dimensions ..... Page 2  
 Wiring ..... Page 3  
 Adjustment ..... Page 3  
 Testing ..... Page 3  
 Accessories & Replacement ..... Page 4



**Approvals**



UL Listed: UL 873 and CSA C22.2 No. 24-93

**Attention**



The installation and maintenance of this product must be done under the supervision of an experienced and trained specialist. Never perform work if gas pressure or power is applied, or in the presence of an open flame.



On completion of installation on the EMP, perform a function test.



Please read the instruction before installing or operating. Keep the instruction in a safe place. You find the instruction also at [www.dungs.com](http://www.dungs.com). If these instructions are not heeded, the result may be personal injury or damage to property.



This product is intended to be used in combination with a control valve to modulate the flow of gas or air.



Any adjustment and application-specific adjustment values must be made in accordance with the equipment manufacturers instructions.

**Explanation of symbols**

- 1, 2, 3 ... = Action
- = Instruction

# Specification

**EMP-1** These actuators meet the requirements for damper control or valve control applications where it is desirable to move the crank arm in either, or to stop it at any point in the stroke by shorting two contacts.



**Electrical Ratings**  
120 VAC (+10 % / -15 %); 60 Hz  
**Electrical Connection**  
1/2" NPT conduit knockout  
**Power Consumption** 78 VA  
**Auxiliary Switch Ratings**  
5.8 A Running; 34.8 A locked rotor

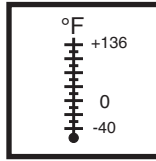

**Ambient Temperature**  
-40 °F to +136 °F (-40 °C to + 58 °C)  
Note: Surface temperature during normal operation can reach 40 °F above ambient.



**Environment and Mounting Position**  
NEMA Type 1; multipoised (best not to have shaft pointing downwards)

**Cycling Rate:**  
EMP is rated for 100 % duty cycling & continuous cycling. Cycle life rating is 100,000 cycles (0-90°/cycle).

**Feedback**  
100 ohm slidewire, standard

Model No.	Order No.	Travel	Description	Timing (s)	Torque (in.- lbs.)	Weight Lbs. (actual/shipping)
EMP-423-1	269235	90°	Fixed timing	12 s	60	9/10
EMP-424-1	269222	90°	Adjustable timing	12 s*	60	9/10
EMP-453-1	267207	90°	Fixed timing	40 s	220	9/10
EMP 454-1	269225	90°	Adjustable timing	40 s*	220	9/10

\* up to ten times the set timing

# Dimensions

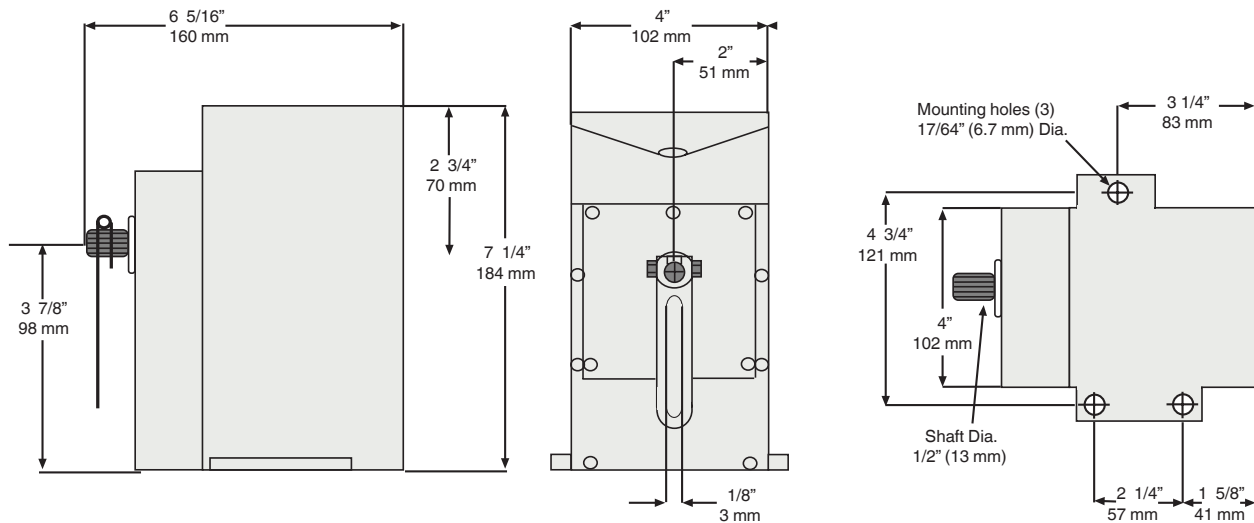

## Wiring

1. Inspect unit before installing, look for broken parts or leaks.
2. Disconnect all power to the actuator before wiring to prevent electrical shock and equipment damage.
3. Do not exceed the electrical ratings given in the specifications and on the actuator.
4. Attach a flexible 1/2" NPT conduit to the actuator. Use NEMA Type 4 compatible type connectors.
5. All connections to the line voltage side of the barrier (L1 and L2, 1, 5 and 6 terminals) must be made with Class 1 wiring.
6. Connect the wiring to the appropriate terminals.
7. Allow 6 inches (152 mm) clearance above the actuator wiring compartment.
8. **When reversing the drive from CCW to CW, exchange wires 7 & 8, and then exchange 2 & 3.**

**⚠ This motor is NOT a "120 VAC Input Drive" type actuator. Do not apply 120 VAC to terminals "X", 2, 3, 4, 7 or 8 or the motor will be permanently damaged.**

**⚠ All wiring must comply with local electrical codes, ordinances and regulations.**

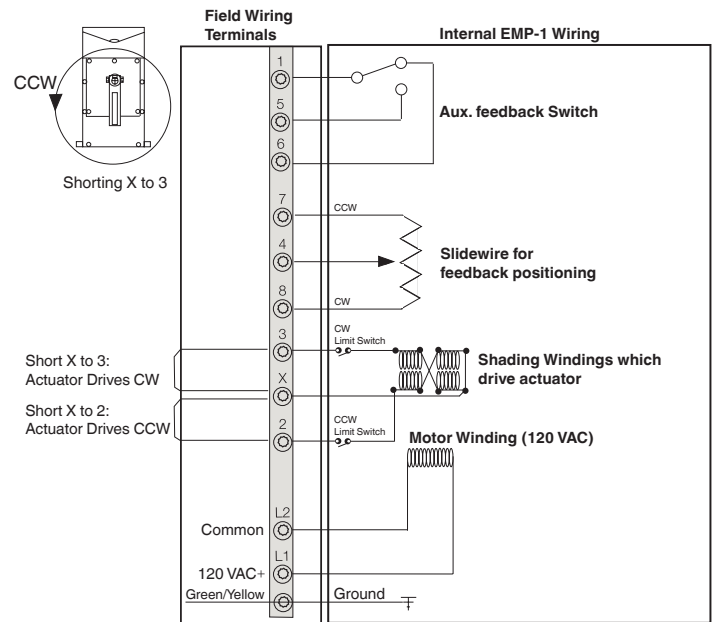

• This wiring diagram shows clockwise rotation to LOW fire, counterclockwise rotation to HIGH fire. As viewed from the front.

- Terminal # 1 is COMMON of the SPDT auxiliary switch
- Terminal # 5 is HIGH FIRE contact
- Terminal # 6 is LOW FIRE contact

• Do NOT apply voltage across slidewire

## Adjustment

### Limit Switch

The counterclockwise limit switch is factory set to stop the actuator after 90° of travel. This setting can be changed in the field. To adjust the limit switch, removing the top metal cover, and locate the small opening next to the terminal block and positioned **between terminals 3 and 4**. Insert a flathead screwdriver through this opening and turn the cam clockwise as seen from the shaft end of the actuator to increase the degree of actuator rotation up to a maximum of 320°. Each click of the cam represents about 3° change in actuator rotation. Attempting to adjust for more than 320° rotation will result in both limit switches opening in the clockwise end of the actuator rotation, and the unit will no longer operate. The clockwise limit switch is fixed and cannot be field adjusted.

**Do not adjust the limit switch beyond 90° unless the standard slidewire has been replaced with a 180° slidewire.**

### Auxiliary Switch

An adjustable cam operated SPDT switch is built into each actuator. The switch is factory set to operate at the clockwise end of the actuator rotation, making terminal 1 to terminal 6. As the cam turns counterclockwise from this point, the cam follower drops, breaking 1 to 6 and making 1 to 5. To adjust

the auxiliary switch, removing the top metal cover, and locate the small opening next to the terminal block and positioned **next to terminal 1**. Insert a flathead screwdriver through this opening and turning the disc clockwise as seen from shaft end of the actuator causes the switch to operate nearer the counterclockwise end of actuator rotation. Each click of the cam represents about 3° change in operating point. **NOTE:** After turning the disc, remove back plate and reposition the wiper; it will need to be repositioned back to zero.

**Speed Adjustment** (EMP-424-1 & EMP-454-1 only) Actuator timing is varied by a slotted adjustment screw on the lower left side of the shaft (Models 424 & 454 only) housing. Turning the screw clockwise decreases the speed. If the adjustment screw is turned too far clockwise, the motor will stall but will not be damaged. If stalling occurs, turn the screw counterclockwise until the motor resumes operation. Total adjustment is normally 3-1/2 turns.

## Testing

Power the actuator with 120 VAC. Disconnect the field lead from terminals X, 2, and 3. Jumper actuator terminal "X" to terminal 2; the actuator shaft should turn CW or CCW. Then jumper actuator terminal "X" to terminal 3; the actuator shaft

should turn in the opposite direction than jumpering X - 2. When the connection between terminals "X" and 2 or 3 is broken, the shaft should remain stationary.

**Accessories & Replacement**

Model #	Description	Order No.	
AM-321-0-2	Auxiliary feedback switch. Two independent SPDT snap switches for position feedback	269234	
ADDA-259-010	135 ohm slidewire; 90 deg	267194	
ADDA-274-010	1000 ohm slidewire; 90 deg	269221	
ADDA-38-010	100 ohm slidewire; 180 deg	269241	
ADDA-902-5	100 ohm 90 deg slidewire and wiper arm kit	269220	
AM 301	90 deg mounting bracket	267191	
AE 504	Paralleling Relay for driving up to 3 actuators with one input signal	269237	
AM 132	5/16" hole; ball joint linkage-swivel connector for non-parallel linking	269232	
AM 122	5/16" hole; straight linkage connector for parallel linking	269233	
AM 113	1/2" crank arm (comes standard)	267224	
AM 116	1/2" splined crank arm (not shown)	267242	
AM 125	5/16" diameter rod (20"long)	267223	
AM 363	NEMA 4 Cover	269239	

We reserve the right to make modifications in the course of technical development.



**Karl Dungs, Inc.**  
3890 Pheasant Ridge Drive NE  
Suite 150  
Blaine, MN 55449, U.S.A.  
Phone 763 582-1700  
Fax 763 582-1799  
e-mail [info@karldungsusa.com](mailto:info@karldungsusa.com)  
Internet <http://www.dungs.com/usa/>

**Karl Dungs GmbH & Co. KG**  
P.O. Box 12 29  
D-73602 Schorndorf, Germany  
Phone +49 (0)7181-804-0  
Fax +49 (0)7181-804-166  
e-mail [info@dungs.com](mailto:info@dungs.com)  
Internet <http://www.dungs.com>