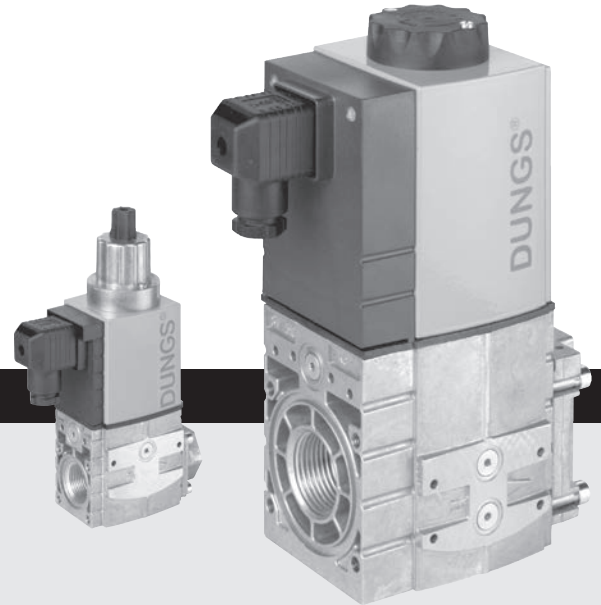



Table of Contents

Table of Contents Page 1
 Approvals Page 1
 Attention Page 1
 Specification Page 2
 Mounting Page 3
 Painting Valve Page 3
 Multiple Burner & Pulse Fired Applications .. Page 3
 Protection from Radiant Heat Page 4
 Wiring Page 4
 Valve Adjustment Page 4
 Test Ports Page 5
 Valve Leakage Test Page 6
 Flow Curve Page 7
 Accessories & Replacement Page 8



Approvals



CSA Certified: File No. 1350312



FM Approved: Report 3014562

Commonwealth of Massachusetts Approved Product Approval code G1-1107-35

Attention



The installation and maintenance of this product must be done under the supervision of an experienced and trained specialist. Never perform work if gas pressure or power is applied, or in the presence of an open flame.

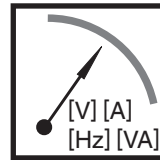

Check the ratings in the specifications verify sure that they are suitable for your application.



Please read the instruction before installing or operating. Keep the instruction in a safe place. You find the instruction also at www.dungs.com If these instructions are not heeded, the result may be personal injury or damage to property.



On completion of work on the safety shutoff valve, perform a leakage and function test.



Any adjustment and application-specific adjustment values must be made in accordance with the equipment manufacturers instructions.



This product is intended for installations covered by, but not limited to, the following codes and standards: CSD-1, NFPA 86, ANSI Z83.4/CSA 3.7, ANSI Z83.18, ANSI Z21.13/CSA 4.9, CSA B149.1, CSA B149.3 (for Canada) or NFPA 37.

Explanation of symbols

- 1, 2, 3 ... = Action
- = Instruction

Specification

SV/604 Normally closed automatic shutoff valve. Fast opening, fast closing.

SV-DLE/604 Normally closed automatic shutoff valve. Slow opening, fast closing. Valve features adjustable max. flow and adjustable initial lift.



Max. Operating Pressure
10 PSI (700 mbar)
Max. Close Off Pressure
15 PSI (1000 mbar)

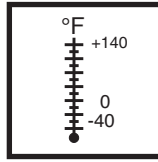

Ambient / Fluid Temperature
-40 °F to +140 °F
(-40 °C to +60 °C)



Electrical Ratings Available
120 VAC / 50 to 60 Hz;
Power Consumption
SV...1005/604 & 1007/604 20 VA
SV...1010/604 & 1012/604 25 VA
SV...1015/604 & 1020/604 45 VA

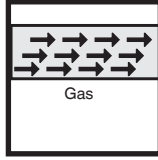

Gases
Dry, natural gas, propane, butane; other noncorrosive gases. Suitable for up to 0.1 % by volume, dry H₂S. A "dry" gas has a dew point lower than + 15 °F and its relative humidity is less than 60 %.



Enclosure Rating
NEMA Type 4 for NEMA 4 indoor only
NEMA Type 12

Materials in contact with Gas
Housing: Aluminium and Steel, free of non-ferrous metals
Sealings on valve seats: NBR-based rubber.

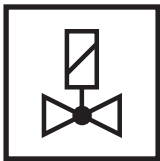

Operating Time
100 % duty cycle
Closing Time
< 1 s
Opening Time
SV/604: < 1 s
SV-DLE/604: 10 to 20 s at 70 °F
Max. Flow Adjustment (SV-DLE/604)
Adjustable: 0 to 100 % of total flow. When adjusted to low flows, flow repeatability upon opening is +/- 15 %
Initial Lift Adjustment (SV-DLE/604)
Adjustable: 0 to 70 % of total flow; 0 to 35 % of stroke

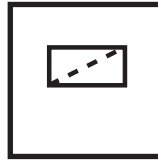

Strainer
23 Mesh, installed in the housing upstream valve seat

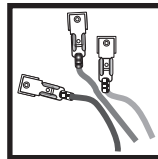

Electrical Connection
DIN-Connector with 1/2" NPT conduit adapter.

Body Size

Size

| | |
|----------------------|------------|
| SV / SV-DLE 1005/604 | 1/2" NPT |
| SV / SV-DLE 1007/604 | 3/4" NPT |
| SV / SV-DLE 1010/604 | 1" NPT |
| SV / SV-DLE 1012/604 | 1 1/4" NPT |
| SV / SV-DLE 1015/604 | 1 1/2" NPT |
| SV / SV-DLE 1020/604 | 2" NPT |

Mounting

Installation Position

Safety shutoff valve from vertically upright to horizontal.



If the flow is not in the same direction of the arrows, the valve will not operate properly.

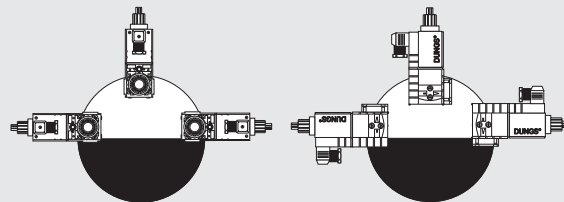

Recommended Preparation

- Examine the SV-(DLE) for shipping damage.
- The main gas supply must be shut off before installing the valve.
- The inside of the SV-(DLE), the flange, and piping must be clean and free of dirt and debris before installing. Failure to remove dirt and debris could result in valve damage and/or improper performance.

Flange Mounting Procedure

1. Verify that the o-ring and the groove is clean and in good condition on the outlet side of the valve.
2. Install the SV-(DLE) with the gas flow matching the direction indicated by the arrows on the casting.
3. Mount the SV-(DLE) with the solenoid vertical upright to horizontal.
4. Clean the mounting surface of the flange.
5. Attach the flange to the outlet of the SV-(DLE) using the screws supplied.
6. Use a 4 mm Allen wrench for the M5 screw.
SV / SV-DLE 1005 & 1007
7. Use a 5 mm Allen wrench for the M6 screw.
SV / SV-DLE 1010, 1012
8. Use a 6 mm Allen wrench for the M8 screw.
SV / SV-DLE 1015, 1020
9. Tighten the screws in a crisscross pattern
10. Do not overtighten the screws. Follow the maximum torque values below.

| Recommended Torque | M5 | M6 | M8 | Screw Size |
|--------------------|----|----|-----|------------|
| | 44 | 62 | 134 | [lb-in] |

Recommended Piping Procedure

- Use new, properly reamed and threaded pipe.
- Apply good quality pipe sealant, putting a moderate amount on the male threads only. If pipe sealant lodges on the valve seat, it will prevent proper operation. If using LP gas, use pipe sealant rated for use with LP gas.
- Do not thread pipe too far. Valve distortion and/or malfunction may result from excess pipe in the valve body.
- Apply counter pressure with a parallel jaw wrench only to the flats on the flange when connecting to pipe.
- Do not overtighten the pipe. Follow the maximum torque values listed below.

| Recommended Torque for Piping | 1/2" | 3/4" | 1" | 1 1/4" | 1 1/2" | 2" | NPT pipe |
|-------------------------------|------|------|-----|--------|--------|------|----------|
| | 375 | 560 | 750 | 875 | 940 | 1190 | [lb-in] |

- After installation, perform a complete leak test using a soapy solution. The presence of bubbles indicates a leak.

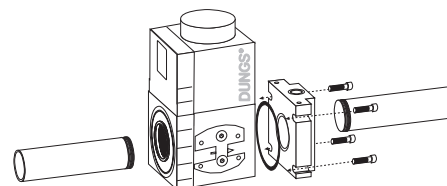

If the flow is not in the same direction of the arrows on the valve body, the valve will not operate properly.

Painting Valve

- It is not recommended that this valve be painted. Painting covers date codes and other labels that identify this valve.
- If the valve needs to be painted, a paint free of volatile organic components (VOC's) must be used. VOC's can damage valve o-rings, resulting in external gas leakage over time.
- During the painting process, use measures that will allow the valve's date code and other labeling information to be legible after the paint is dry.

Multiple Burner & Pulse Fired Applications

On **multiple burner applications**, the following requirements apply:

- A manually operated shutoff valve shall be installed downstream of each individual burner safety shutoff valve.
- The backpressure on the individual burner safety shutoff valve shall be measured during the commissioning of the furnace to verify that while all other burners are firing and the individual burner safety shutoff valve shall is de-energized, the backpressure does not exceed 2 PSI. Measuring the backpressure shall also be repeated during purge and post purge. A pressure gauge can be used to measure the backpressure.

When using these valves on **pulse fired applications**, the following apply:

- Before installing the valve, the inside of all gas piping upstream to the nearest filter shall be cleaned, and that filter shall have an insert with mesh no larger than 50 micron.
- The valve shall be installed in the upright position.
- The valve shall be applied within all of its ratings. The type of gas, the ambient temperature, and the cycle rate of the valve are critical.
- The valve shall be leak tested as least annually.
- After the cycle life has been exceeded, the valve shall be immediately replaced.

Protection from Radiant Heat

- Radiant heat must be considered as a heat source that could result in an ambient temperature higher than the rating of this valve.
- Provide proper shielding to protect against radiant heat.

Wiring

Wiring the SV-(DLE)

1. Disconnect all power to the valves before wiring to prevent electrical shock and equipment damage.
2. Attach flexible 1/2" NPT conduit to the DIN connector.
3. Route 14 or 16 gauge wire rated for at least 75 °C (167 °F) through the conduit and the DIN connector.
4. Connect the wiring to the appropriate screw terminals in the DIN connector.
5. Plug the DIN connector onto the terminals. Fasten the DIN connector with the screw supplied.



All wiring must comply with local electrical codes, ordinances and regulations.

Electrical connection IEC 730-1 (VDE 0631 T1)

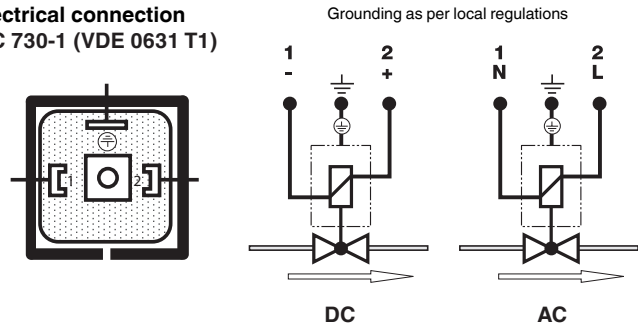

Valve Adjustment

Max. Flow Adjustment (SV-DLE only)

- The SV-DLE is factory set with the max. flow adjustment fully open.



Before making a max. flow adjustment, the valve should be properly piped in the application.

1. Locate the max. flow adjustment on top of the SV-DLE (base of the hydraulic brake). There are two screws, the holding screw is recessed and has a blue sealing compound on it, while the pan head screw protrudes from the cap.
2. Loosen the pan head screw until you can freely rotate the flow adjustment.
3. Turn clockwise for less gas or counterclockwise for more gas.
4. Check the flow at the burner with an orifice or flow meter.
5. Tighten the pan head screw on the adjustment cap after adjustments are completed.

Max. Flow Setting

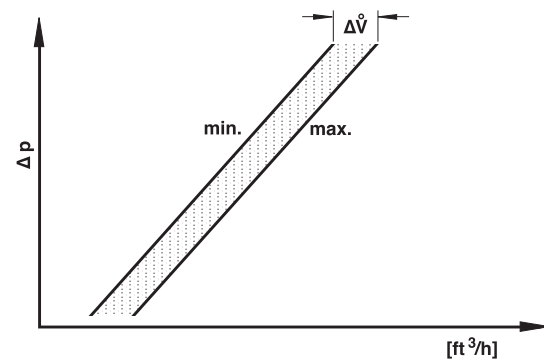

Initial Lift Adjustment

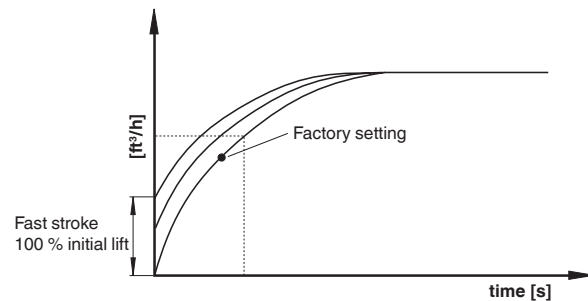

Initial Lift Adjustment (SV-DLE only)

The initial lift adjustment varies the initial gas flow through the valve as the valve seat begins to open. This adjustment can allow the initial gas flow to 0 % and 70 % of the total gas flow; 0 to 25 % of stroke, within 1 second. All SV-DLE valves are factory set with no initial lift (100 % slow opening). To adjust the lift proceed as follows:

1. Unscrew the small black cap on top of the flow adjustment cap to expose the initial lift adjustment knob.
2. The black cap also serves as tool; turn the cap over and insert it on the slot on the adjustment knob.
3. Turn the knob clockwise for a min. initial lift or counterclockwise for a max. initial lift.
4. Once the desired initial fast lift has been achieved, reinstall the black cap.

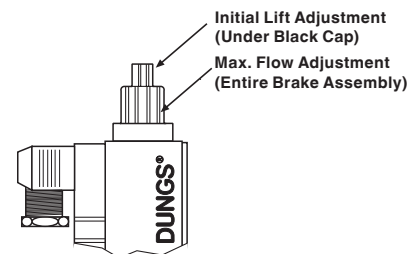

Do not adjust or remove any screws or bolts which are sealed with a Red colored compound. Doing so will void all approvals and warranties.

Test Ports

G1/8 ISO 228 test ports available on both sides of the valve. Each side has one test port upstream (2), one downstream (3) of the valve seat. One Inlet (1) and outlet (4) of valve body. The SV 1010, 1012, 1015, and 1020 have one outlet (5) on valve flange. The G 1/8 test nipple (Order No. 219008) can be screwed into any of the test ports.

⚠ The position of the side taps #2 and #3 on the SV 1005/1007 are not the same as on the SV 1010-1020 valves.

SV-(DLE): 1005, 1007

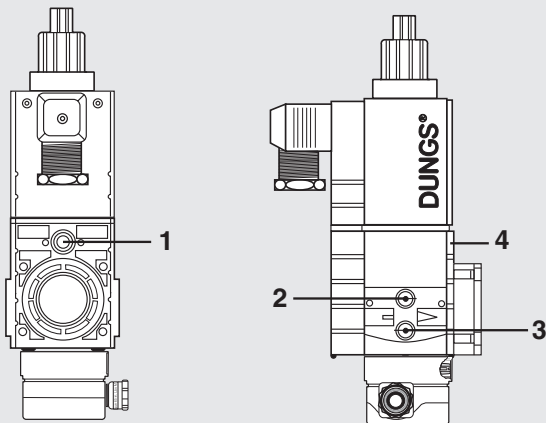
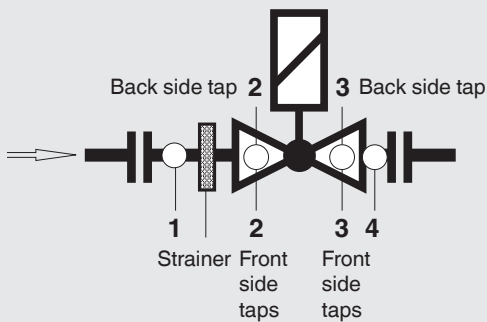

SV-(DLE): 1010, 1012

SV-(DLE): 1015, 1020

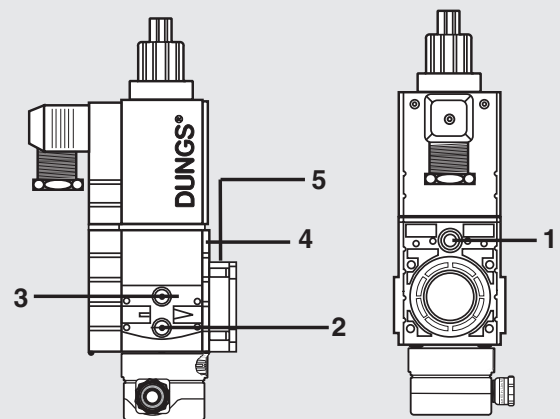
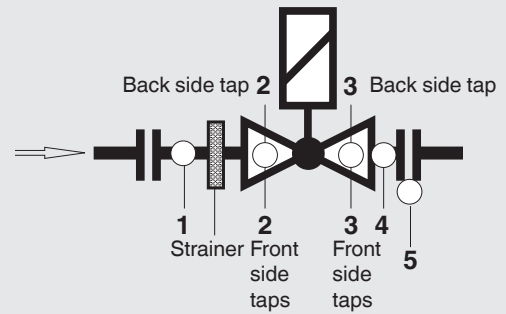

Valve Leakage Test

This leak test procedure tests the external sealing and valve seat sealing capabilities of two SV automatic safety shutoff valves in series. Only qualified personnel should perform this test.

It is required that this test be done on the initial system startup, and then repeated at least annually. Possibly more often depending on the application, environmental parameters, and the requirements of the authority having jurisdiction.

Setup

This test requires the following:

- Test nipples installed in the downstream pressure tap port of each automatic safety shutoff valve to make the required 1/4" hose connection in step 4.
- A transparent glass of water filled at least 1 inch from the bottom.
- A proper leak test tube. An aluminum or copper 1/4" rigid tube with a 45° cut at the end that is then connected to a 1/4" flexible hose of some convenient length provides for a more accurate leakage measurement. However, a 45° cut at the end of the 1/4" flexible hose will suffice, but it will not likely be as accurate as the rigid tube.
- For detecting external leakages, an all purpose liquid leak detector solution or a soapy water solution is required.

Leak Test Procedure

Use the illustration below as a reference.

- With the upstream ball valve open, the downstream ball valve closed and both valves energized, apply an all purpose liquid leak detector solution to the "External Leakage Test Areas" indicated in the illustration below, to any accessories mounted to the safety valve, and to all gas piping and gas components downstream the equipment isolation

valve, and the inlet and outlet gas piping for each automatic safety shutoff valve. The presence of bubbles indicates a leak, which needs to be rectified before proceeding.

- Then, de-energize the burner system and verify that both automatic safety shutoff valves are closed.
- Close the upstream and downstream manual ball valve.
- Open the downstream test nipple of the upstream valve, and connect the 1/4" flexible hose to the test nipple.
- Slowly open the upstream manual ball valve, and then provide for some time to allow potential leakage to charge the test chamber before measuring valve seat leakage.
- Immerse the 1/4 in. tube vertically 1/2 in. (12.7 mm) below the water surface. If bubbles emerge from the 1/4" tube and after the leakage rate has stabilized, count the number of bubbles appearing during a 10 second period. (See chart below for allowable leakage rates.)
- Repeat the procedure for the downstream automatic safety shutoff valve except that valve #1 needs to be opened during the leakage test.

After completing the above tests proceed as follows:

- Verify that the downstream manual ball valve is closed, and both automatic safety shutoff valves are de-energized.
- Remove the flexible hose, and close all test nipples.
- With the upstream manual ball valve open, energize both automatic safety shutoff valves.
- Use soapy water to leak test all test nipples to ensure that there are no leaks.
- If no leakage is detected, de-energize all automatic safety shutoff valves, and open the downstream manual ball valve.

 If leakage values are exceeded, replace valve immediately.

 The position of the side taps #2 and #3 on the SV 1005/1007 are not the same as on the SV 1010-1020 valves.

Step 1: Leak Test Here

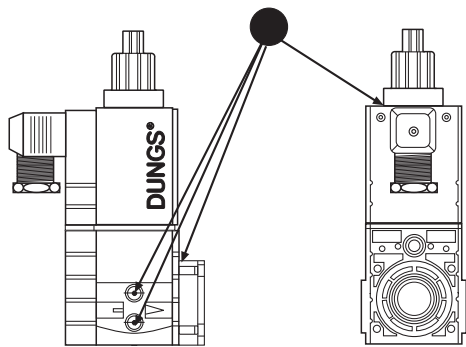

SV-(DLE): 1005, 1007

SV-(DLE): 1010, 1012, 1015, 1020

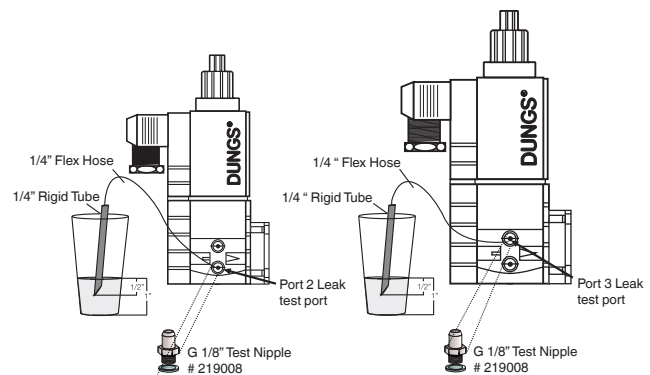

| Type | Allowable Valve Seat Leakage* up to 10 PSI inlet | # of Bubbles in 10 s | | |
|--------------------|--|----------------------|-------------|----|
| | | Air | Natural Gas | LP |
| SV-(DLE) 1005/1007 | 239 cc/hr | 5 | 6 | 4 |
| SV-(DLE) 1010/1012 | 464 cc/hr | 9 | 11 | 7 |
| SV-(DLE) 1015/1020 | 588 cc/hr | 10 | 12 | 8 |

*Based on air and test conditions per UL 429 Section 29. (Air or inert gas at a pressure of 1/4 psig and also at a pressure of one and one-half times maximum operating pressure differential, but not less than 1/2 psig. This test shall be applied with the valve installed in its intended position.)
Volume of bubble defined in Table 2 of FCI 70-2-1998.

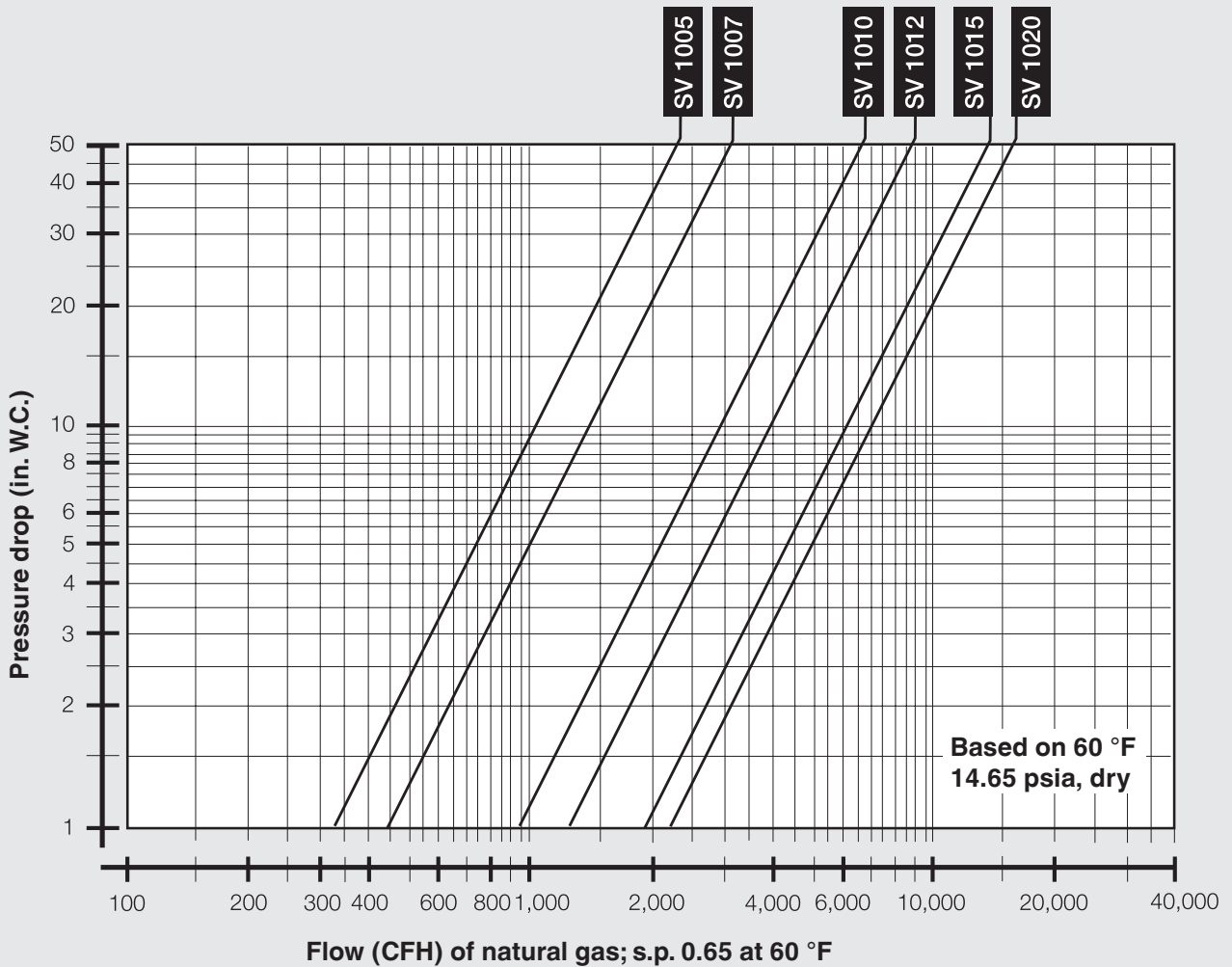

Pressure drop for other gases

To determine the pressure drop when using a gas other than natural gas, use the flow formula below and f value located in the table below to determine

the “corrected” flow rate in CFH through the valve for the other gas used. For example, when using propane, divide the volume (CFH) of propane required for the application by the calculated value

f (f = 0.66 for propane). Use this “corrected” flow rate and the flow curve on the next page to determine pressure drop for propane.

Determining equivalent flow through valves using another gas

$$\dot{V}_{\text{gas used}} = \dot{V}_{\text{Natural gas}} \times f$$

$$f = \sqrt{\frac{\text{Density of Natural gas}}{\text{Density of gas used}}}$$

| Type of gas | Density [kg/m ³] | s.g. | f |
|-------------|------------------------------|------|------|
| Natural gas | 0.81 | 0.65 | 1.00 |
| Butane | 2.39 | 1.95 | 0.58 |
| Propane | 1.86 | 1.50 | 0.66 |
| Air | 1.24 | 1.00 | 0.80 |

Accessories & Replacement

Valve Accessories

| *Flange kit | Size | Replacement Coil (120 VAC) | Part # NPT Flange Kit* | Part # Rp Flange Kit* | Coil Cover | Part # PCB Board |
|----------------|-------|----------------------------|------------------------|-----------------------|------------|------------------|
| SV 1005 / 1007 | 1/2 | 246502 | 242650 | 242220 | 254740 | 245147 |
| SV 1005 / 1007 | 3/4 | 246502 | 242651 | 242221 | 254740 | 245147 |
| SV 1010 / 1012 | 1/2 | 246503 | 242653 | 242223 | 254741 | 245153 |
| SV 1010 / 1012 | 3/4 | 246503 | 242654 | 242224 | 254741 | 245153 |
| SV 1010 / 1012 | 1 | 246503 | 242655 | 242225 | 254741 | 245153 |
| SV 1010 / 1012 | 1 1/4 | 246503 | 242656 | 242226 | 254741 | 245153 |
| SV 1010 / 1012 | 1 1/2 | 246503 | 245563 | 243817 | 254741 | 245153 |
| SV 1015 / 1020 | 1 | 246504 | 242657 | 242227 | 254741 | 245153 |
| SV 1015 / 1020 | 1 1/4 | 246504 | 242658 | 242228 | 254741 | 245153 |
| SV 1015 / 1020 | 1 1/2 | 246504 | 242659 | 242229 | 254741 | 245153 |
| SV 1015 / 1020 | 2 | 246504 | 242659 | 242230 | 254741 | 245153 |

*Mounting kit includes 1 flange, 4 bolts and 1 O-ring.

Valve Accessories

| | Order No. |
|--|-----------|
| Electrical Plug (DUNGS / DIN Connector) | 210319 |
| M20 - 1/2" NPT Adapter | 240671 |
| Valve Indicator | 266949 |
| 1/4" NPT Adapter | 225047 |
| 1/8" Test Nipple | 219008 |
| 1/2" NPT Pilot Gas Adapter | 225043 |



Karl Dungs, Inc.
 3890 Pheasant Ridge Drive NE
 Suite 150
 Blaine, MN 55449, U.S.A.
 Phone 763 582-1700
 Fax 763 582-1799
 e-mail info@karldungsusa.com
 Internet <http://www.dungs.com/usa/>

Karl Dungs GmbH & Co. KG
 P.O. Box 12 29
 D-73602 Schorndorf, Germany
 Phone +49 (0)7181-804-0
 Fax +49 (0)7181-804-166
 e-mail info@dungs.com
 Internet <http://www.dungs.com>