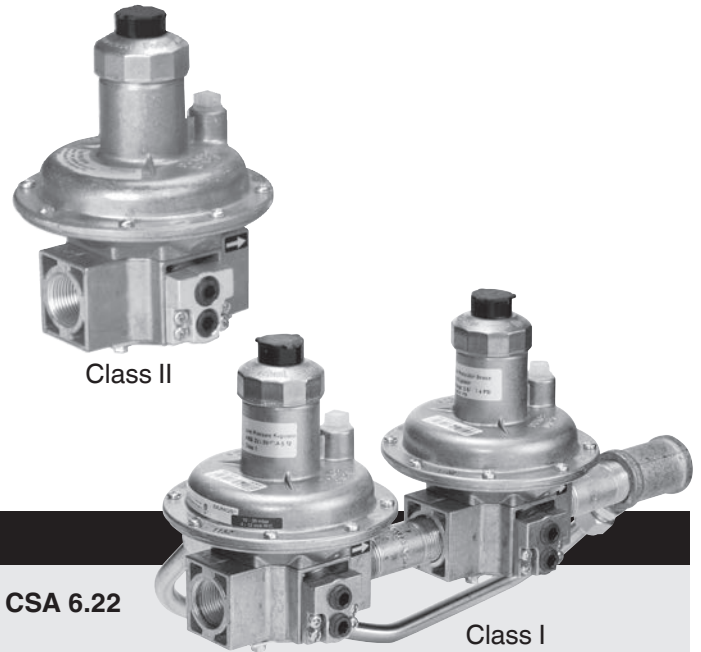



Table of Contents

Table of Contents Page 1
 Approvals Page 1
 Attention Page 1
 Specification Page 2
 Lock-up Pressure Parameters..... Page 3
 Mounting Preparation..... Page 3
 Mounting & Installation Page 4
 Pressure Tap Connections..... Page 5
 Outlet Pressure Spring Selection..... Page 6
 Breather Plug Page 6
 Vent Limiting Device & Vent Line Connection Page 7
 External Impulse Page 7
 Outlet Pressure Adjustment Page 8
 Spring Replacement..... Page 8
 Flow Curve Page 9
 Repair Kits Page 10



Approvals



FRS 7../6 series are CSA Certified: ANSI Z21.80 / CSA 6.22

Commonwealth of Massachusetts Approved Product Approval code G1-1107-35

Attention



The installation and maintenance of this product must be done under the supervision of an experienced and trained specialist. Never perform work if gas pressure or power is applied, or in the presence of an open flame.



On completion of work on the pressure regulator, perform a leakage and function test.



Please read the instruction before installing or operating. Keep the instruction in a safe place. You find the instruction also at www.dungs.com If these instructions are not heeded, the result may be personal injury or damage to property.



This product is intended for installations covered by, but not limited to, the following codes and standards: NFPA 54, International Fuel Gas Code, and CSA B149.1



Any adjustment and application-specific adjustment values must be made in accordance with the equipment manufacturers instructions.

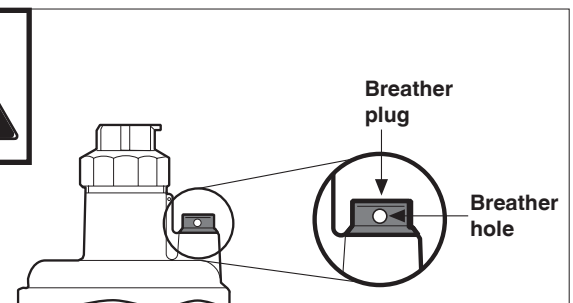

Never close Breather hole!

Explanation of symbols

- 1, 2, 3 ... = Action
- = Instruction

Specification

FRS The FRS series balance type, pressure regulator is a spring-loaded pressure regulator with adjustable setpoint spring and an internal sensor for regulating output pressure.



Max. Operating Pressure (MOP)
 10 PSI (700 mbar) for FRS 7.../6 series.
 5 PSI (350 mbar) applies to the CSA
 Certification for FRS 7.../6.

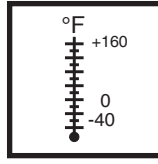

Ambient / Fluid Temperature
 FRS 7.../6 series:

- +5 °F to +160 °F for up to 10 PSI for regulating behavior (+/- 10 % of setpoint)
- CSA Certified for -40 °F to +160 °F: Diaphragms are suitable for the low temperature, but there may be out of range regulating behavior.

Output pressure range
 Adjustable with different springs
 1 - 15" W.C. as Class I
 16" W.C. - 2 PSI as Class II



Maximum pressure drop and gas velocity
 The maximum pressure drop is limited by the velocity of the gas. Do not exceed a gas velocity of 30 meters/s.

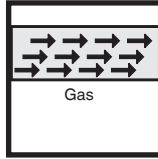

Gases

Dry, natural gas, propane, butane; other noncorrosive gases. Suitable for up to 0.1% by volume, dry H₂S. A "dry" gas has a dew point lower than +15 °F and its relative humidity is less than 60 %.

Materials in contact with Gas

Housing: Aluminum & Steel
 Seals & Diaphragm: NBR-based rubber.

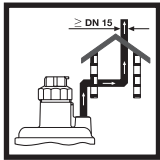

Vent Limiting Device and Vent Line Connection
 The FRS/6 has an internal, factory installed vent limiter, which limits the escape of gas to less than 0.5 CFH @ 5 PSI in case atmospheric diaphragm ruptures. Vent limiting device also complies with EN 88-1 & ISO 23551-2. Venting required unless otherwise accepted by the authority having jurisdiction.



Droop and Hysteresis

Hysteresis is less than 10 % for up to 7 PSI inlet.
 Average droop at 20:1 turndown is 10 % for up to 7 PSI.

Lock-up Rating

- The FRS meets the ANSI Z.21.80/ CSA 6.22 as Class I, which allows lockup rating not more than 150" or 5 in. W.C, whichever is greater.
- The FRS meets EN 88-1 as SG30, which allows lock-up as high as +30 % of the outlet pressure.
- See Lock-up Pressure Parameters on page 3 for more details.

Body Size	Size	Order No. Class I	Order No. Class II
FRS 705/6	1/2" NPT	267002	269319
FRS 707/6	3/4" NPT	269320	267004
FRS 710/6	1" NPT	269321	267006
FRS 712/6	1 1/4" NPT	269322	267008
FRS 715/6	1 1/2" NPT	267010	269323
FRS 720/6	2" NPT	267012	267013
FRS 725/6	2 1/2" NPT	269325	269326
FRS 730/6	3" NPT	269328	269329

Lock-up Pressure Parameters

Per ANSI Z21.80, lock-up is defined as an outlet pressure not more than 150 % or 5 in. W.C, whichever is greater, above the setpoint after a downstream safety shutoff valve closes with 2 seconds, and the two following conditions exists:

1. Outlet pressure is set to the highest set point of the spring, and
2. The regulator is set to maximum capacity or flow at which the regulator will control lockup pressure within the acceptable limits.

This means that in a given application, a lockup greater than 150 % or 5 in. W.C could occur, depending out the inlet pressure, the outlet pressure of the regulator, the flow rate of the regulator, and the pipe volume downstream the regulator and upstream the safety shutoff valve.

Per DUNGS, lock-up is +30 % of the outlet pressure setting after downstream shutoff valve slowly closes within 30 seconds. Therefore, in a given application, a lockup greater than +30 % or 5 in. W.C could occur, depending out the inlet pressure, the outlet pressure of the regulator, the flow rate of the regulator, and the pipe volume downstream the regulator and upstream the safety shutoff valve.

If in a given application the lock-up pressure is too high, employing one or more of the following should reduce the lock-up pressure:

1. Increase the size of the regulator.
2. Increase the pipe volume downstream the regulator and upstream the safety shutoff valve.
3. Decrease the inlet pressure.
4. Decrease the outlet pressure.
5. Reduce the flow rate.
6. Disconnect vent line, if installed.

Mounting Preparation

Mounting Preparation

- The main gas supply must be shut off before starting the installation.
- Carefully examine the unit for shipping damage.
- Remove all dirt and debris before installing.
- Failure to remove dirt/debris could result in damage or improper performance.

Recommended Mounting Procedure

Regulator dome from vertically upright to horizontal

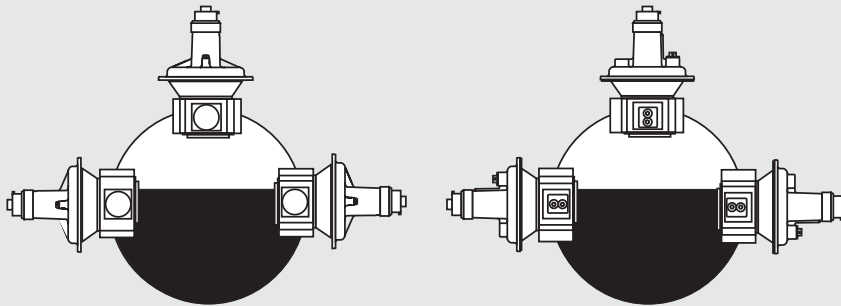

If the flow is not in the same direction of the arrows, the regulator will not operate properly.

Mounting & Installation

Procedure to Mount the FRS 7../6

- Install the FRS.../6 with the gas flow matching the direction indicated by the arrows on the casting.
- Mount the FRS.../6 with the regulator dome vertical or horizontal.
- Use new, properly reamed and NPT threaded pipe free of chips.
- Apply good quality pipe sealant, putting a moderate amount on the male threads only. If using LP gas, use pipe sealant rated for use with LP gas.
- Do not thread pipe too far. FRS.../6 distortion and/or malfunction may result from excess pipe in the valve body.
- Apply counterpressure with a parallel jaw wrench only to the flats of the FRS.../6 when installing pipe.
- Do not overtighten the pipe. Follow the maximum torque values listed.

- After installation is complete, perform a leak test using a soapy water solution.



Quickly opening the inlet manual shutoff valve can permanently rupture the internal, balancing diaphragm.

FRS 7../6 Threaded Series

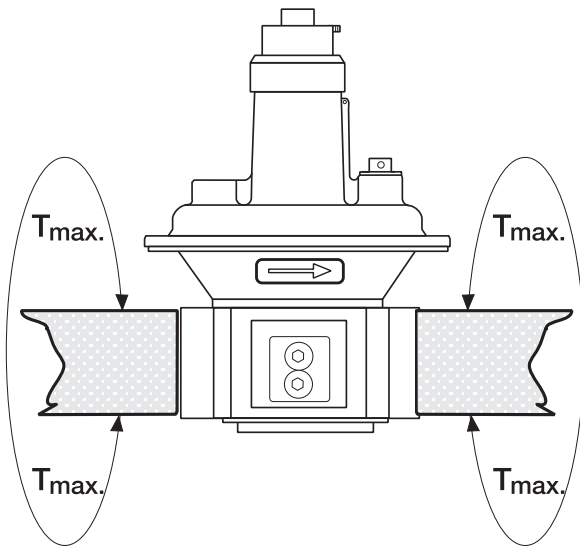

NPT pipe	1/2"	3/4"	1"	1 1/4"	1 1/2"	2"	2 1/2"	3"
T _{max} [lb-in]	443	560	750	875	940	1190	1310	1310



Do not overtorque threaded connection or bolts. Permanent damage will occur.



If the flow is not in the same direction as the arrows, the FRS will not operate properly.

NOTE: There are no limits for required pipe lengths immediately downstream of the FRS.

Pressure Tap Connections

Pressure Taps - FRS 7../6 Threaded Version

- 1 Vent/breather connection
FRS 705/6 - FRS 710/6, G 1/4 in.
FRS 712/6 - FRS 730/6, G 1/2 in.
- 2 External feedback pressure connection
FRS 705/6 - FRS 710/6, G 1/4 in. - one side.
FRS 712/6 - FRS 730/6, G 1/4 in. - both sides.
- 3 Upstream pressure connection
FRS 705/6 - FRS 710/6, 1/4 in. NPT - one side.
FRS 705/6 - FRS 710/6, G 1/4 in. - one side.
FRS 712/6 - FRS 730/6, 1/4 in. NPT - both sides.
- 4 Downstream pressure connection
FRS 705/6 - FRS 710/6, 1/4 in. NPT - one side.
FRS 712/6 - FRS 730/6 1/4 in. NPT - both sides.

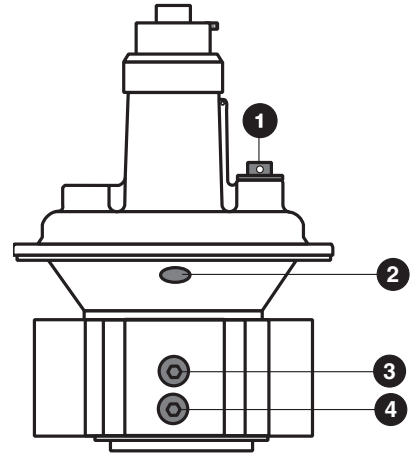

When using external feedback pressure connection, the internal feedback tube must be sealed with RTV.

Outlet Pressure Spring Selection

Outlet Pressure Spring Selection (outlet pressure values are for horizontal pipe mounting)

The output pressure is controlled by the force of the adjustable spring. The pressure regulator is supplied with the blue spring No. 4. By exchanging springs, other output pressures can be attained. Subtract 1"W.C. when mounted vertically.

FRS 7../6 Type	Order No. as Class I	Regulator Outlet pressure range as Class I	Monitoring Regulator as Over-pressure Protection device. Outlet Pressure Protection Range
FRS 705/6	267002	4 - 12 in. W.C.	10 - 22 in. W.C.
FRS 707/6	269320	4 - 12 in. W.C.	10 - 22 in. W.C.
FRS 710/6	269321	4 - 12 in. W.C.	10 - 22 in. W.C.
FRS 712/6	269322	4 - 12 in. W.C.	10 - 22 in. W.C.
FRS 715/6	267010	4 - 12 in. W.C.	10 - 22 in. W.C.
FRS 720/6	267012	4 - 12 in. W.C.	10 - 22 in. W.C.
FRS 725/6	269325	4 - 12 in. W.C.	10 - 22 in. W.C.
FRS 730/6	269328	4 - 12 in. W.C.	10 - 22 in. W.C.

FRS 7../6 Type	Order No. as Class II	Regulator Outlet pressure range as Class II
FRS 705/6	269319	24 - 40 in. W.C.
FRS 707/6	267004	24 - 40 in. W.C.
FRS 710/6	267006	24 - 40 in. W.C.
FRS 712/6	267008	24 - 40 in. W.C.
FRS 715/6	269323	24 - 40 in. W.C.
FRS 720/6	267013	24 - 40 in. W.C.
FRS 725/6	269326	24 - 40 in. W.C.
FRS 730/6	269329	24 - 40 in. W.C.

Breather Plug

- All FRS's have a breather plug that threads into the regulator's vent connection.
- The FRS regulator must also be able to exchange air through the breather hole in order to properly regulate. Do not plug the breather hole. Clear out if necessary.

⚠ Do not removed plastic breather plug unless venting outdoors is required.

This plug is not the vent limiter, and it prevents debris from entering the upper chamber of the regulator. Debris in the upper chamber of the regulator could adversely affect regulator performance.

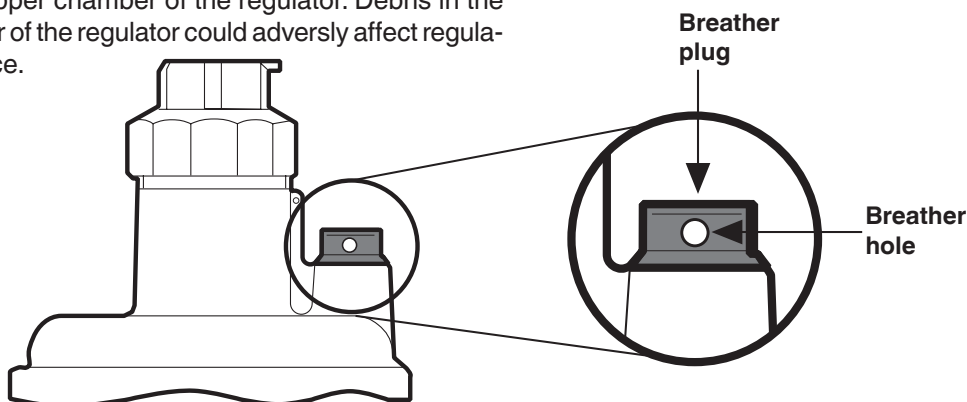

Vent Limiting Device & Vent Line Connection

Vent Limiting Device

The FRS/6 series regulator contains an internal, factory installed vent limiting device, which limits the escape of gas to less than 0.5 CFH @ 5 PSI in case atmospheric diaphragm ruptures. Venting required unless accepted by the authority having jurisdiction.

Vent Line Requirements

- Follow the local code for vent sizing and termination requirements. In the absence of local codes, follow National Fuel Gas Code NFPA 54, the International Fuel Gas Code or the CSA B149.1 installation code for venting requirements.
- Terminate the vent to an approved location.
- At the point of termination, the vent line must be protected from insects and water intrusion. It is highly recommend to install an insect screen and terminate the pipe with the exit facing downwards to prevent rain water from entering. **NOTE:** For appliances using direct spark ignition, DUNGS recommends using the FRS's factory installed, internal vent limiting device rather than installing a vent line. Vent lines can cause resistance or even feedback pressures that increase the lock-up pressure, potentially leading to hard light-offs or even damaging the appliance.

Installation Procedure

- If venting the regulator, the vent line is to be connected to the upper dome of the FRS regulator as illustrated.
- Remove the beather plug.
- On indoor installations requiring venting outdoors, run the piping as short and as direct as possible.
- The vent connector is G 1/4 for FRS 705/6 to FRS 710/6 and G 1/2 for FRS 712/6 to FRS 730/6 and for all ISO flanged regulators. G 1/4 to 1/4" NPT adapters are available: (part number 231944) and G 1/2 to 1/2 NPT (part number 231945).

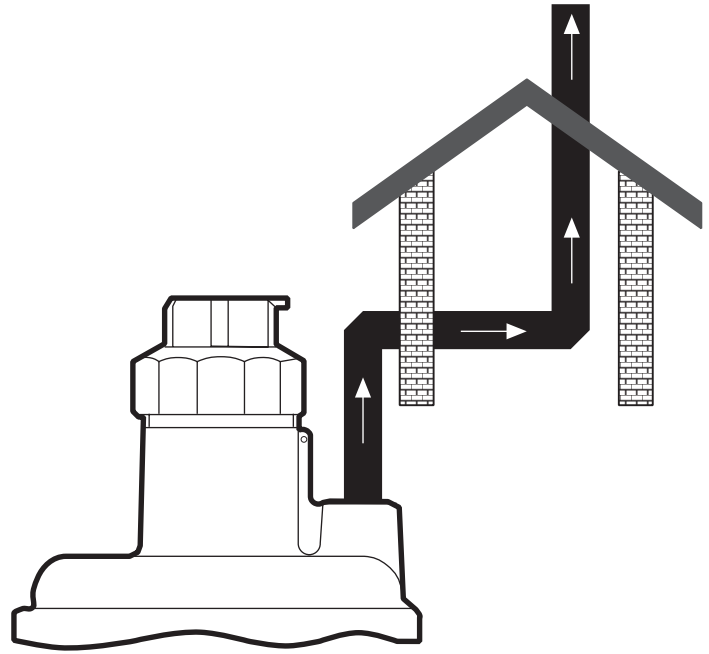

In the absence of venting codes and where venting is required, each regulator must be vented separately from all other vents.

External Impulse

- When it is desirable to use the external impulse as the feedback for the regulator, the internal impulse must be plugged. Seal the internal impulse connection with a silicone or RTV sealant suitable for exposure to natural gas, propane, or butane.
- The external impulse must be properly terminated and made of a durable, metal material that is suitable for gas service.

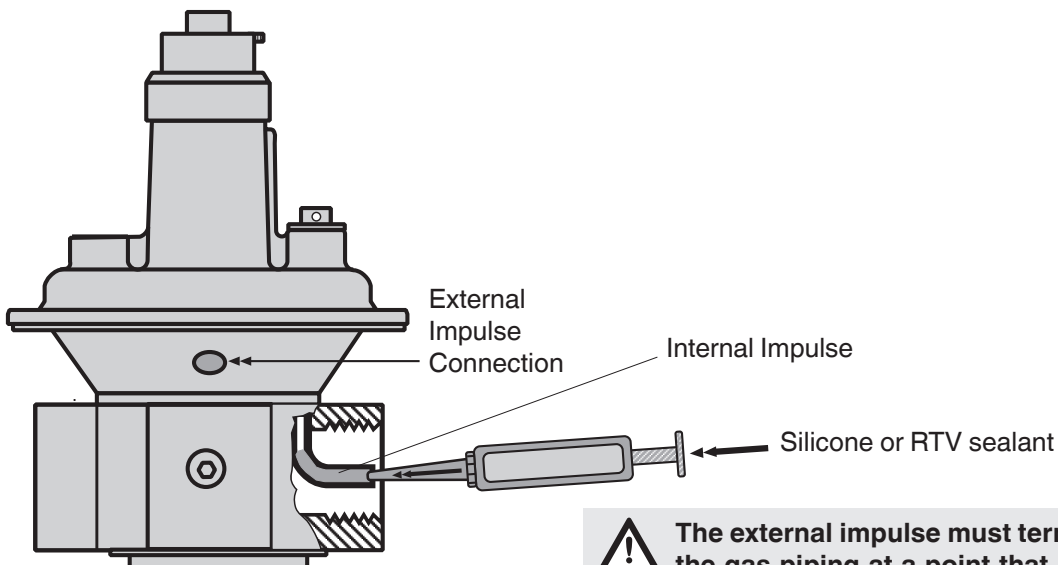

The external impulse must terminate back into the gas piping at a point that is upstream two safety shutoff valves in series.

Outlet Pressure Adjustment

Adjusting the FRS outlet pressure

1. Verify that the intended output pressure is within the spring range that is installed in the regulator by comparing the colored outlet pressure label with the table on page 6.
2. Remove the black cover.
3. To increase outlet pressure, turn the adjustment spindle clockwise. To decrease the outlet pressure, turn the adjustment spindle counterclockwise.
4. Always use an accurate pressure gauge connected downstream of the regulator to measure the actual outlet pressure as the FRS is mounted in the operating position.
5. Reinstall the black adjustment cover.
6. To prevent unauthorized adjustment, holes in the black cover and the side of the regulator can be used to secure a lead seal.

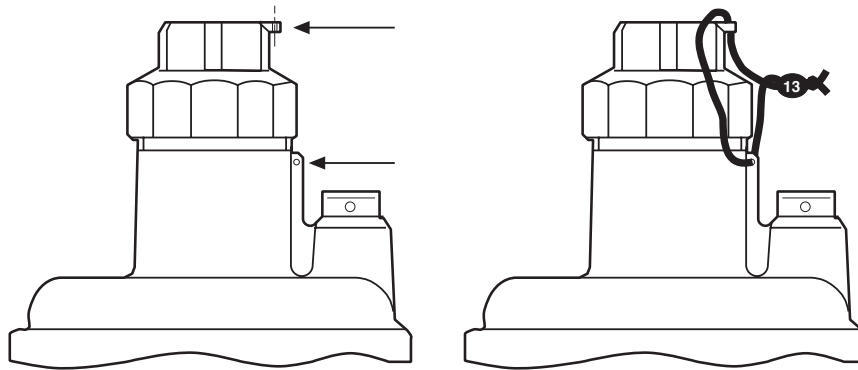
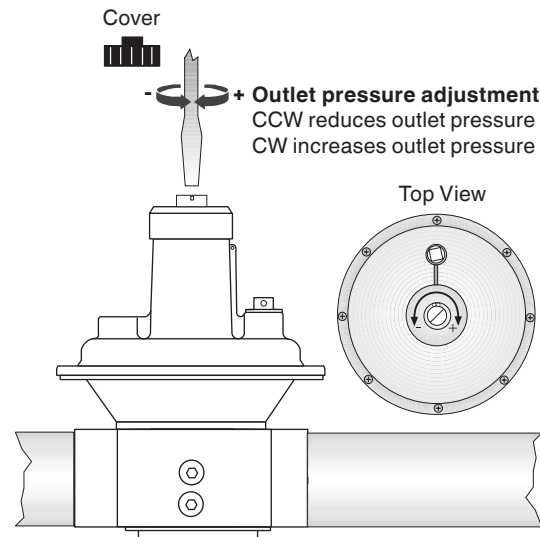

Spring Replacement

Spring Replacment

- Remove the adjustment cover.
- Completely release the spring tension by turning the adjustment spindle completely counterclockwise with a screwdriver, and remove the aluminum cap.
- Remove existing spring and insert new spring.
- Re-install the adjusment cover, and apply the new outlet pressure label provided with new outlet pressure range onto the name plate.
- Reinstall the adjustment cover.



Never have your head above or near the aluminum cap when removing regulator spring. The spring tension can be high enough to rapidly eject the aluminum cap with a large force.

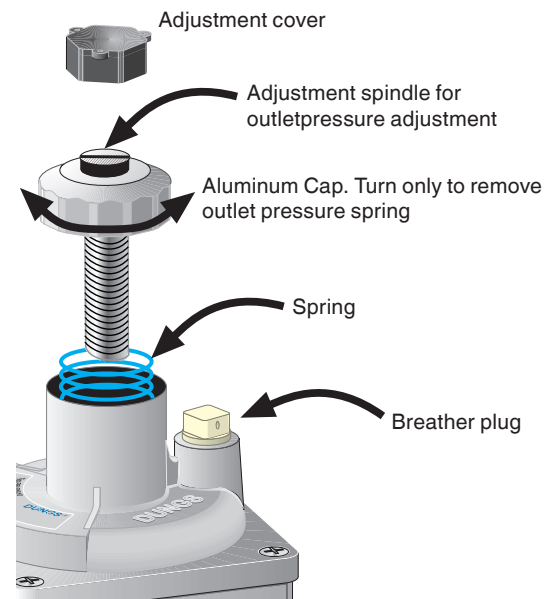

Flow Curve

Flow Curve Using Natural Gas for class II regulator.

Use as a quick reference for sizing a regulator in the regulated state at:

Outlet pressure = 8 in. W.C.

Inlet pressure = 20 in. W.C.

$V_{min} = 0.05 \times V_{max}$

Flow tables for other outlet pressures are available

Pressure drop for a Class I regulator is in worst case twice the value of the Class II regulator.

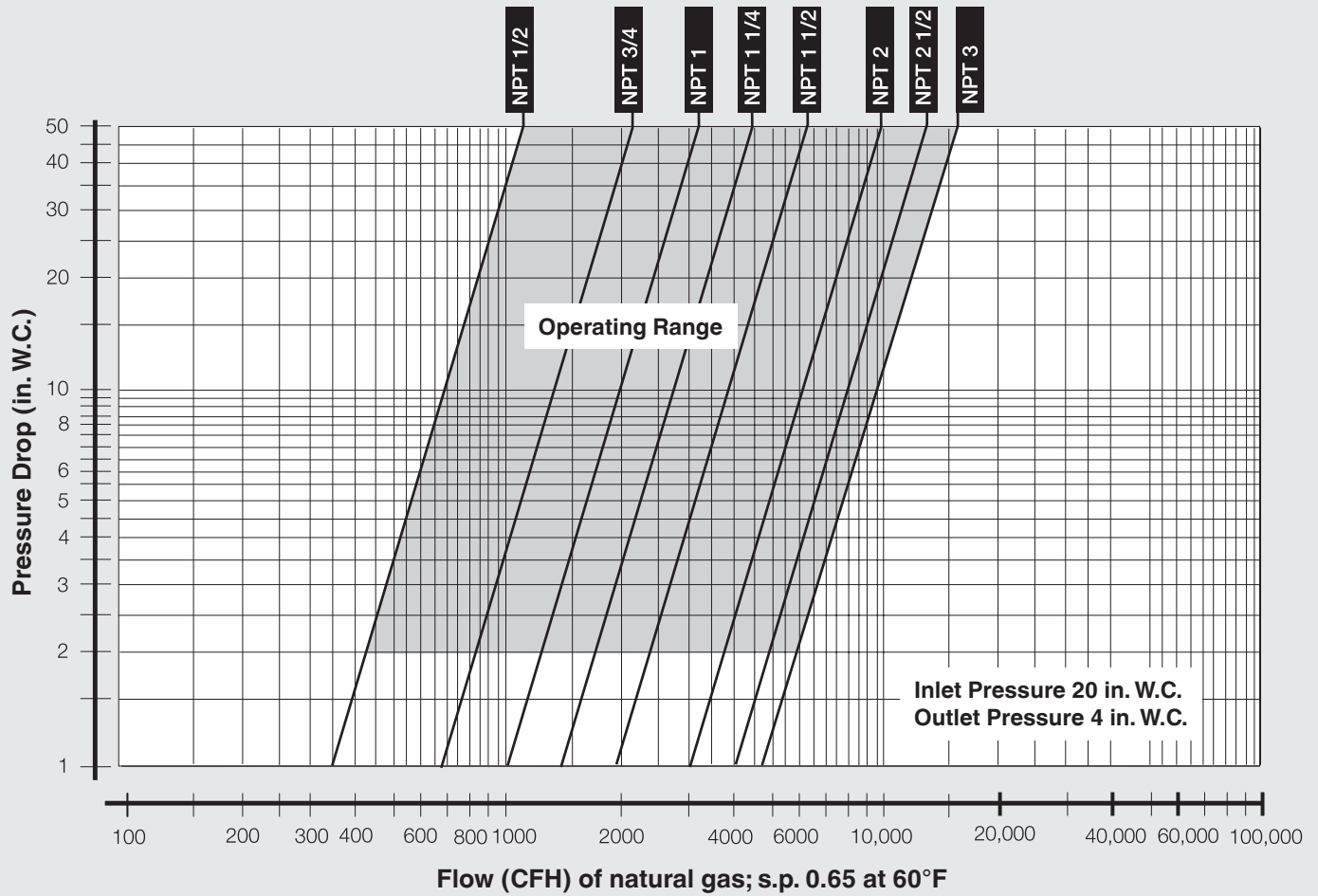

Repair Kits

Repair Kit (contains all internal hardware to rebuild regulator)	Part #
FRS 705/6	Not available
FRS 707/6	Not available
FRS 710/6	Not available
FRS 712/6, 715/6	068924
FRS 720/6	068932

Repair Kit (contains all internal hardware to rebuild regulator)	Part #
FRS 725/6	068940
FRS 730/6	091868

We reserve the right to make any changes in the interest of technical progress.



Karl Dungs, Inc.
3890 Pheasant Ridge Drive NE
Suite 150
Blaine, MN 55449, U.S.A.
Phone 763 582-1700
Fax 763 582-1799
e-mail info@karldungsusa.com
Internet <http://www.dungs.com/usa/>

Karl Dungs GmbH & Co. KG
P.O. Box 12 29
D-73602 Schorndorf, Germany
Phone +49 (0)7181-804-0
Fax +49 (0)7181-804-166
e-mail info@dungs.com
Internet <http://www.dungs.com>