

# Dual Modular Safety Shutoff Valves

DMV-D/11 Series  
DMV-DLE/11 Series

**DUNGS**<sup>®</sup>  
Combustion Controls



Tollfree in Western Canada: 1-888-388-1592  
microwatt.com • mwsales@microwatt.com

SALES • SERVICE • SUPPORT



**Two normally closed safety shutoff valves in one housing; each with the following approvals.**

#### CSA Certified

- ANSI Z21.21
- CSA 6.5
- Marked C/I
- File # 157406

#### FM Approved

- Class 7411
- File # J.I. 3007653

#### Commonwealth of Massachusetts Approved Product

- Approval code G1-1107-35
- Gas Safety Shutoff Valve

#### EU Gas Appliance Directive

- EN161
- CE-0087AU30

#### Codes and Standards

This product is intended for installations covered by but not limited to NFPA 86, NFPA 37, CSA B149.1, CSA B149.3 and CSA 149.6

**DUNGS is an ISO 9001 manufacturing facility.**



#### Description

The DUNGS Dual Modular Valve (DMV) combines two safety shutoff valves in one compact housing, which can be wired independently or in parallel.

Valve 1 (V1) of the DMV-D and DMV-DLE series is fast opening and fast closing. Valve 2 (V2) of the DMV-D is fast opening, while V2 of the DMV-DLE is slow-opening for smoother light-off. Max. flow adjustment on V1 provides variable main flow on both models.

Internal profiles and compact design optimize flow and provide a low pressure drop.

Directly mounting the following DUNGS accessories creates a compact valve train without additional piping:

- High and low gas pressure switches
- Valve proving system
- 1" NPT Vent line adapter

#### Application

The DUNGS DMV is recommended for industrial and commercial heating applications that require two safety shutoff valves. The DMV Dual Modular Valve is suitable for dry natural gas, propane, butane, air and other inert gases. Suitable for up to 0.1% by volume, dry H<sub>2</sub>S.

A "dry" gas has a dew point lower than +15 °F and its relative humidity is less than 60 %.

**DMV-D.../11** Two normally closed safety shutoff valves in one housing. V1 and V2 are fast opening, fast closing. Adjustable max. flow with V2.

**DMV-DLE.../11** Two normally closed safety shutoff valves in one housing. V1 fast opening, fast closing. V2 is slow opening, fast closing. Adjustable max. flow and adjustable initial lift with V2.

### Specifications

Flange sizes	DN 40 (1 1/2") 50 (2") 65 (2 1/2") 80 (3") 100 (4") 125 (5") Connection flange as per DIN 2501 Part 1, to fit pre-weld flanges as per DIN 2633 (PN 16) DN 40 to DN 125, ISO 7005 - 1 (PN 16), or ISO 7005 - 2 (PN 16).
Max. operating pressure	7 PSI (500 mbar) CSA, FM, CE (Class A)
Max. body pressure	15 PSI (1000 mbar)
Max. close off pressure	7 PSI (500 mbar) CSA, FM, CE (Class A)
Electrical ratings (+10 % / -15 %)	110 - 120 VAC @ 50 - 60 Hz and 24 VDC. Part numbers listed on page 3. 220 - 240 VAC @ 50 - 60 Hz
Enclosure rating	NEMA Type 12
Electrical connection	DIN-connector with 1/2" NPT conduit adapter (order separately)
Operating time	100 % duty cycle
Closing time	< 1 s
Opening time (to max. flow)	DMV-D.../11 V1 & V2 < 1 s DMV-DLE.../11 V1 < 1 s; V2 Adjustable to approx. 10 to 20 s at 70 °F
Initial lift adjustment	Adjustable on V2 DLE only; 0 to 70 % of total flow; 0 to 25% of stroke
Max. flow adjustment	Adjustable on V1 <10 to 100 % of total flow; <10 to 100% of stroke
Materials in contact with gas	Housing: Aluminium, Steel; free of non-ferrous metals Sealings on valve seats: NBR-based rubber
Ambient temperature rating	+5 °F to +140 °F (-15 °C to +60 °C)
Installation position	Safety shut off valve from vertically upright to horizontal
Gas strainer (standard)	Installed in the housing upstream V1 (23 mesh)
Position indication (order separately)	CPI 400 with indication lamps and SPDT interlock switch or Visual indicator (VI)
Test ports / Pressure switch mounting ports	G 1/8 ISO 228 ports available on both sides. Each side has two ports upstream V1, one between V1 and V2, one downstream V2. G 1/4 ISO 228 on both flanges, upstream of V1, downstream of V2
Valve proving system	VPS 504; mounts directly to either side of DMV

Power Ratings					
Version	Coil Type	Approx. Power Rating [VA] @ 120 VAC	Approx. Power Rating [VA] @ 24 VDC	Approx. Current [A] @ 120 VAC	Approx. Current [A] @ 24 VDC
DMV-D(LE) 5040/11	1212	90	70	3.8	2.6
DMV-D(LE) 5050/11	1212	90	70	3.8	2.6
DMV-D(LE) 5065/11	1411	110	90	4.6	3.8
DMV-D(LE) 5080/11	1511	110	95	4.6	4.0
DMV-D(LE) 5100/11	1611	135	95	5.6	4.0
DMV-D(LE) 5125/11	1711	200	155	8.3	6.5

Dimensions inch (mm)

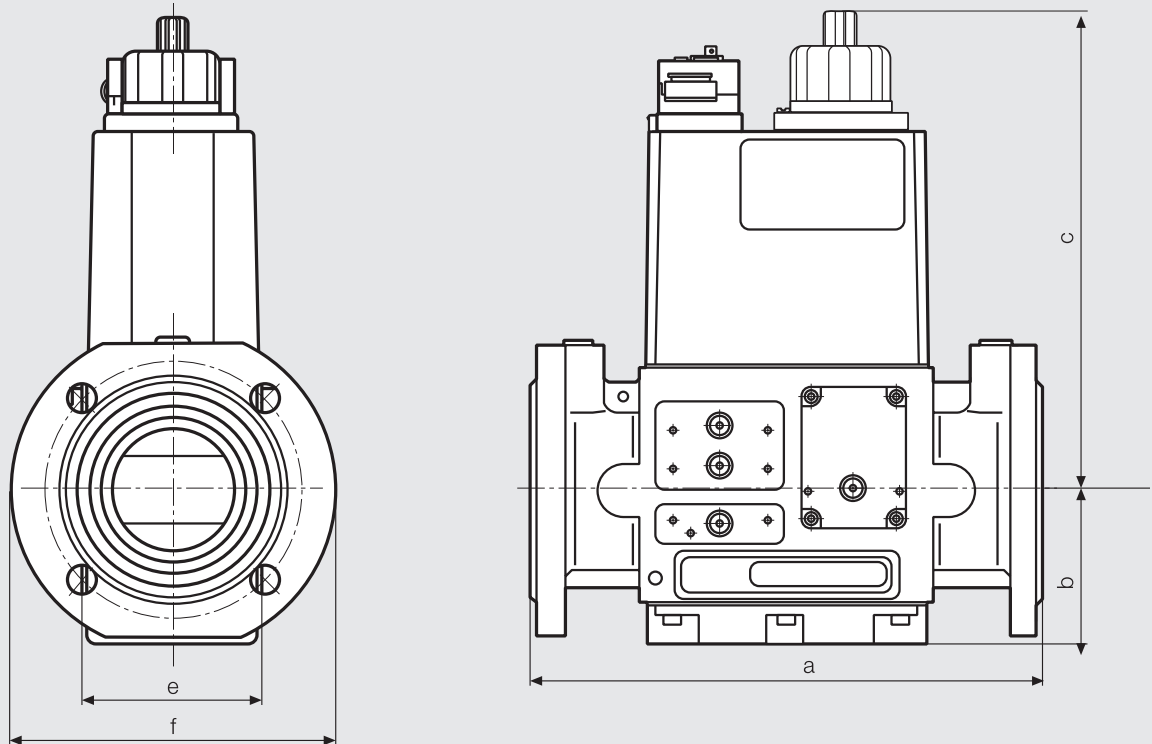

Type	110 - 120 VAC @ 50 - 60 Hz Order No.	24 VDC Order No.	P <sub>max.</sub> [PSI]	Connection DN	Dimensions [inch] Dimensions [mm]					Weight [lbs] [kg]
					a	b	c	e	f	
DMV-D 5040/11	226061	226063	7	DN 40	9.5	2.5	7.6	3.9	5.9	17.2
					240	62,5	192	100	150	7,8
DMV-D 5050/11	226064	226066	7	DN 50	9.5	2.9	7.6	3.9	6.5	18.3
					240	73	192	100	165	8,3
DMV-D 5065/11	226067	226069	7	DN 65	11.4	3.4	9.9	4.0	7.3	32.2
					290	87	251	102	185	14,6
DMV-D 5080/11	226070	226072	7	DN 80	12.2	4.1	11.5	5.1	7.9	52.0
					310	104	293	129	200	23,6
DMV-D 5100/11	226073	226075	7	DN 100	13.8	4.7	13.0	5.6	8.7	67.5
					350	119	331	143	220	30,6
DMV-D 5125/11	226076	226078	7	DN 125	15.8	5.6	16.2	6.3	10.0	111.6
					400	142	412	161	255	50,6
DMV-DLE 5040/11	226115	226117	7	DN 40	9.5	2.5	8.7	3.9	5.9	17.4
					240	62,5	220	100	150	7,9
DMV-DLE 5050/11	226118	226120	7	DN 50	9.5	2.9	8.7	3.9	6.5	18.5
					240	73	220	100	165	8,4
DMV-DLE 5065/11	226102	226103	7	DN 65	11.4	3.4	10.6	4.0	7.3	32.6
					290	87	269	102	185	14,8
DMV-DLE 5080/11	226104	226106	7	DN 80	12.2	4.1	12.3	5.1	7.9	53.1
					310	104	312	129	200	24,1
DMV-DLE 5100/11	226112	226114	7	DN 100	13.8	4.7	15.1	5.6	8.7	68.6
					350	119	382	143	220	31,1
DMV-DLE 5125/11	226108	226110	7	DN 125	15.8	5.6	18.2	6.3	10.0	112.7
					400	142	462	161	255	51,1

Equipment variants of DMV.../11 double solenoid valve, single-stage mode	DMV 5040/11 - DMV 5125/11
DMV-D	X
DMV-DLE	X
Sieve	X
Gas pressure switch can be mounted: on flange	X
downstream of sieve	Possible using a pipe nipple (X)
downstream of valve 2	(X)
Valve V1, double-seat	X
Valve V2, double-seat	X
Valves opening separately	X
G 3/4 ignition gas flange can be mounted	(X)

X	standard
(X)	on request
-	not possible

Required Flanges & Accessories						
Body Size	Flange Description	# of Holes per Flange	* Flange Order No.	Bolt size	**Bolt Order No.	***Gasket Order No.
DMV-D(LE) 5040/11	1 1/2" ISO Flanged	4	227137	M16x55	135930	267463
DMV-D(LE) 5050/11	2" ISO Flanged	4	227138	M16x65	135930	267464
DMV-D(LE) 5065/11	2 1/2" ISO Flanged	4	227139	M16x65	135930	267465
DMV-D(LE) 5065/11	2 1/2" ISO to NPT	4	243690	M16x65	135930	267465
DMV-D(LE) 5080/11	3" ISO Flanged	8	227140	M16x65	135930	267466
DMV-D(LE) 5080/11	3" ISO to NPT	8	243219	M16x65	135930	267466
DMV-D(LE) 5100/11	4" ISO Flanged	8	227141	M16x65	135930	267467
DMV-D(LE) 5125/11	5" ISO Flanged	8	227142	M16x75	148830	267468

\*When a control is used alone, one mating flange is needed for each end, for a total of two flanges.

When one control is bolted to another, such as an FRS to a DMV, one mating flange is needed for each end, for a total of two flanges.

\*\*includes one bolt, one lock washer, and one nut.

\*\*\*one gasket needed for each flange connection.

## Dual Modular Valve (DMV) system

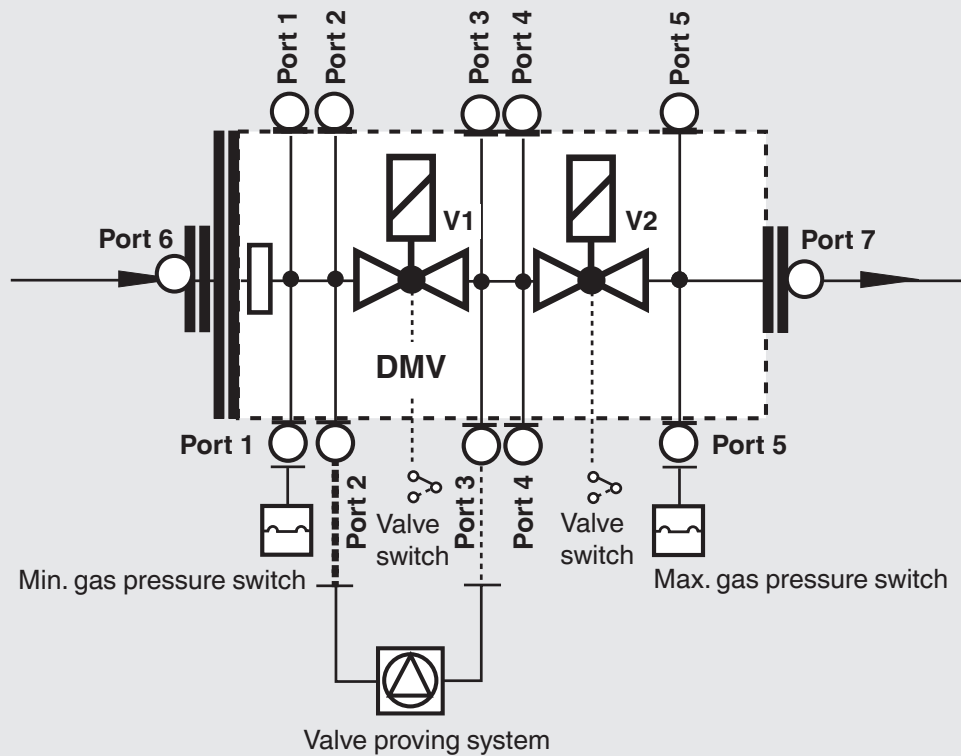

### Additional Accessories

#### VPS 504

Valve proving system (approved by some authorities having jurisdiction in lieu of vent valve and “proof of closure” e.g. FM and Swiss Re).

#### GAO/GMH/GML A2 pressure switch

#### Position indication

**CPI 400** with indication lamps and SPDT interlock switch, or Visual indicator (VI)

#### DMK butterfly control valve

Mounts directly downstream of DMV to modulate gas flow. Requires actuator. Use DMA actuator with DMK butterfly valve.

#### Adapters

- 1/4" NPT adapter (225047)
- 1/2" NPT Pilot gas adapter; Check flow requirements. (225043)
- G 1/8" Test nipple (219008)
- 1" NPT Vent line adapter (243760)

### Pressure drop for other gases

To determine the pressure drop when using a gas other than natural gas, use the flow formula below and f value located in the table below to determine

the “corrected” flow rate in CFH through the valve for the other gas used. For example, when using propane, divide the volume (CFH) of propane required for the application by the calculated value

f (f = 0.66 for propane). Use this “corrected” flow rate and the flow curve on the next page to determine pressure drop for propane.

### Determining equivalent flow through valves using another gas

$$\dot{V}_{\text{gas used}} = \dot{V}_{\text{Natural gas}} \times f$$

$$f = \sqrt{\frac{\text{Density of Natural gas}}{\text{Density of gas used}}}$$

Type of gas	Density [kg/m <sup>3</sup> ]	s.g.	f
Natural gas	0.81	0.65	1.00
Butane	2.39	1.95	0.58
Propane	1.86	1.50	0.66
Air	1.24	1.00	0.80

Dual Modular Safety  
Shutoff Valves

DMV-D/11 Series  
DMV-DLE/11 Series



Flow curve

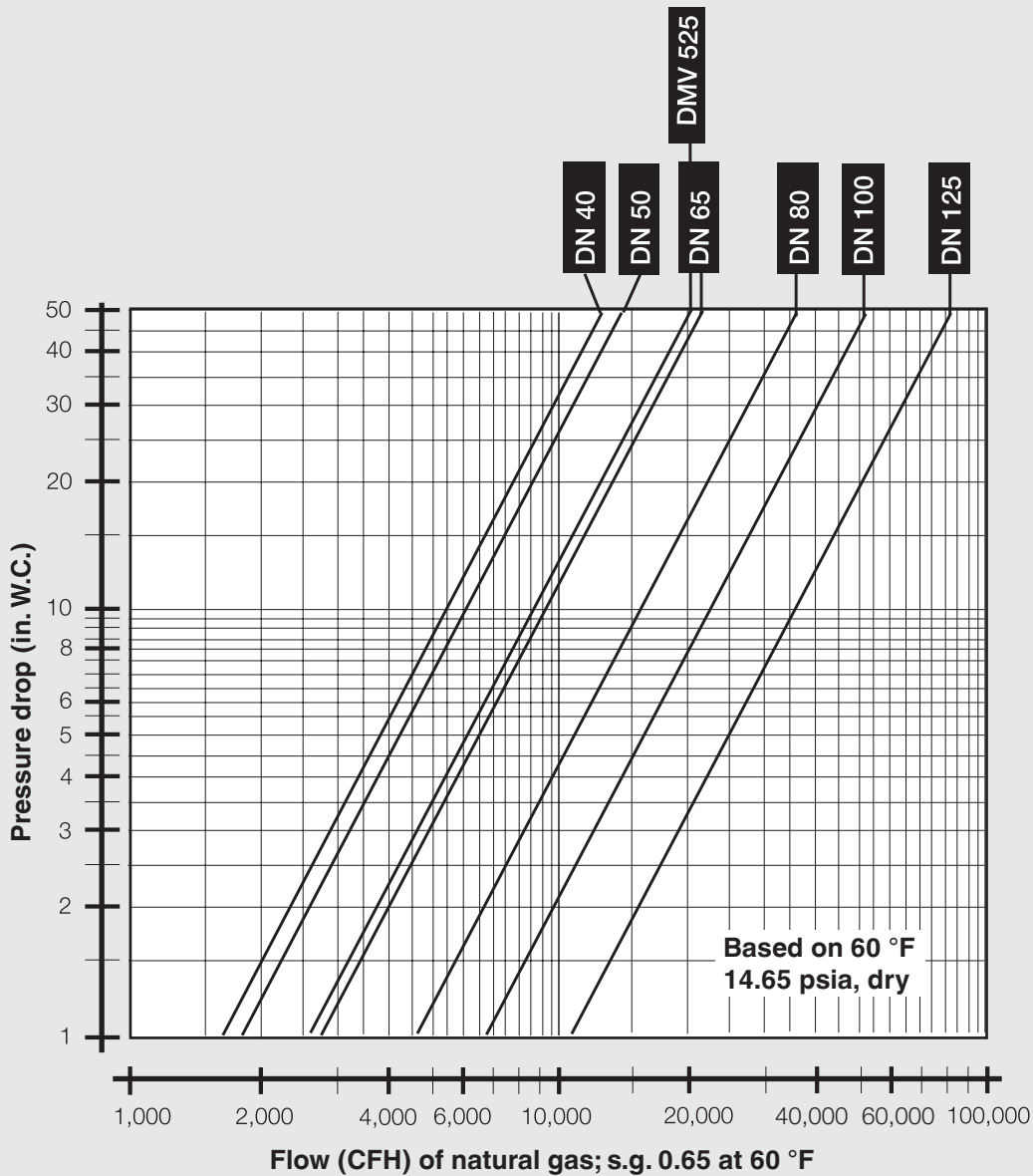

We reserve the right to make any changes in the interest of technical progress.



Karl Dungs, Inc.  
3890 Pheasant Ridge Drive NE  
Suite 150  
Blaine, MN 55449, U.S.A.  
Phone 763 582-1700  
Fax 763 582-1799  
e-mail [info@karldungsusa.com](mailto:info@karldungsusa.com)  
Internet <http://www.dungs.com/usa/>

Karl Dungs GmbH & Co. KG  
P.O. Box 12 29  
D-73602 Schorndorf, Germany  
Phone +49 (0)7181-804-0  
Fax +49 (0)7181-804-166  
e-mail [info@dungs.com](mailto:info@dungs.com)  
Internet <http://www.dungs.com>