



# AudioMaster® Public Address 30 Watt Speaker

Model AM30T

## PUBLIC ADDRESS FOR INDUSTRIAL ENVIRONMENTS

- Transformer Coupled
- 25, 70, or 100 Vrms
- 30 watt
- Omni-directional swivel mount
- Constant directivity horn design
- Type 3R enclosure

The Federal Signal AM30T is a transformer-coupled, constant directivity, re-entrant speaker ideal for most public address or paging applications. The constant directivity design provides excellent sound coverage throughout the frequency range of speech. The AM30T is molded from impact resistant, beige acrylic-styrene-acrylonitrile (ASA). The omni-directional swivel mount of this speaker allows the unit to be pointed anywhere within a 360° half-sphere of area.

Power handling for the AM30T is 30 watt with transformer taps of 30, 15, 7.5, 3.7, and 1.8. A screwdriver operated power switch is used to select the desired tap. This unit is designed for use in 25, 70, and 100 Vrms distributed systems.

The driver of the AM30T employs a rugged phenolic diaphragm, a 1.5-inch diameter voice coil, and "rim centered" ferrite magnet structure for long life and durability under extreme operating conditions. A 12-inch connecting cable, phased and color coded, is provided for connecting the AM30T.

The AM30T can be used with the AudioMaster® CTS series amplifiers and the AudioRouter™ to complete an industrial grade public address system.

Model	Power Handling	Frequency Response	Transformer	Power Taps	Beam Width	Decibels @ 10'	Decibels @ 1m
AM30T	30 watt	400-6500Hz	25 Vrms 70 Vrms 100 Vrms	15, 7.5, 3.7, 1.8 30, 15, 7.5, 3.7, 1.8 30, 15, 7.5, 3.7	80° x 50°	112	122



## PUBLIC ADDRESS SPEAKER (AM30T)

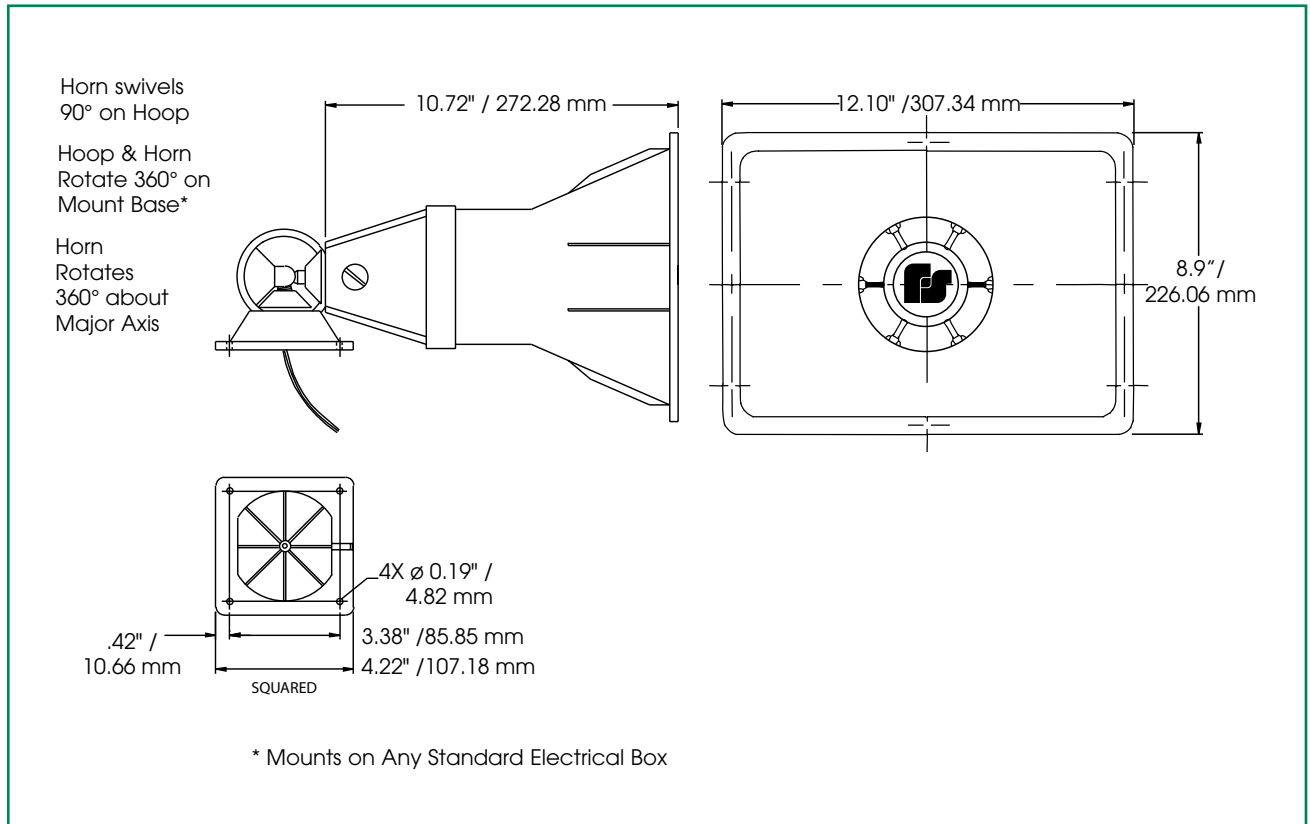

### SPECIFICATIONS

Net Weight:	5.3 lbs.	2.4 kg
Shipping Weight:	5.8 lbs.	2.6 kg
Height:	8.9"	22.6 cm
Width:	12.1"	30.7 cm
Depth:	12.2"	31.0 cm

### HOW TO ORDER

- Specify model number

