



# Remotely Selectable Electronic Siren

## Model SST3-MV

### ELECTRONIC SIREN WITH THREE REMOTELY SELECTABLE TONES

- Multi-voltage design accepts 24VDC and 120/240VAC
- Produces three tones – wail, yelp and horn
- Produces 109.5-111dBA @ 10'
- Omni-directional swivel mount
- Type 3R enclosure (with WB back box)
- UL and cUL Listed

Federal Signal's SST3-MV is an electronic siren capable of producing three different high decibel tones from the same unit.

The Model SST3-MV features internal amplification and the circuitry required to produce three different tones. The user activates each tone (wail, yelp or horn) with dry contacts from a remote point.

The SST3-MV operates on 24VDC, 120VAC or 240VAC. The NEMA 3R housing is molded from impact resistant ASA (acrylic-styrene-acrylonitrile) plastic, making it resistant to ultra-violet light and ideal for indoor or outdoor use.

The omni-directional swivel mount system allows the output to be pointed anywhere within a 360° half-sphere.

This electronic siren is UL and cUL Listed.

The Model SST3-MV can be used as a stand-alone, high-output, audible warning device in any application where multiple tones are needed but voice paging is not required.

Typical applications include emergency warning, start and dismissal, fire alarm, general alarm and evacuation.

Federal Signal's Model SST3-MV Electronic Siren is an economical multi-tone siren designed to hold up in the rigors of corrosive environments.

Model	Voltage	Operating Current	Decibels @	
			10'	1m
SST3-MV	24VDC	600 mA	<b>Wail</b>	109.5 119.5
SST3-MV	120VAC	210 mA	<b>Yelp</b>	111.0 121.0
SST3-MV	240VAC	120 mA	<b>Horn</b>	107.0 117.0

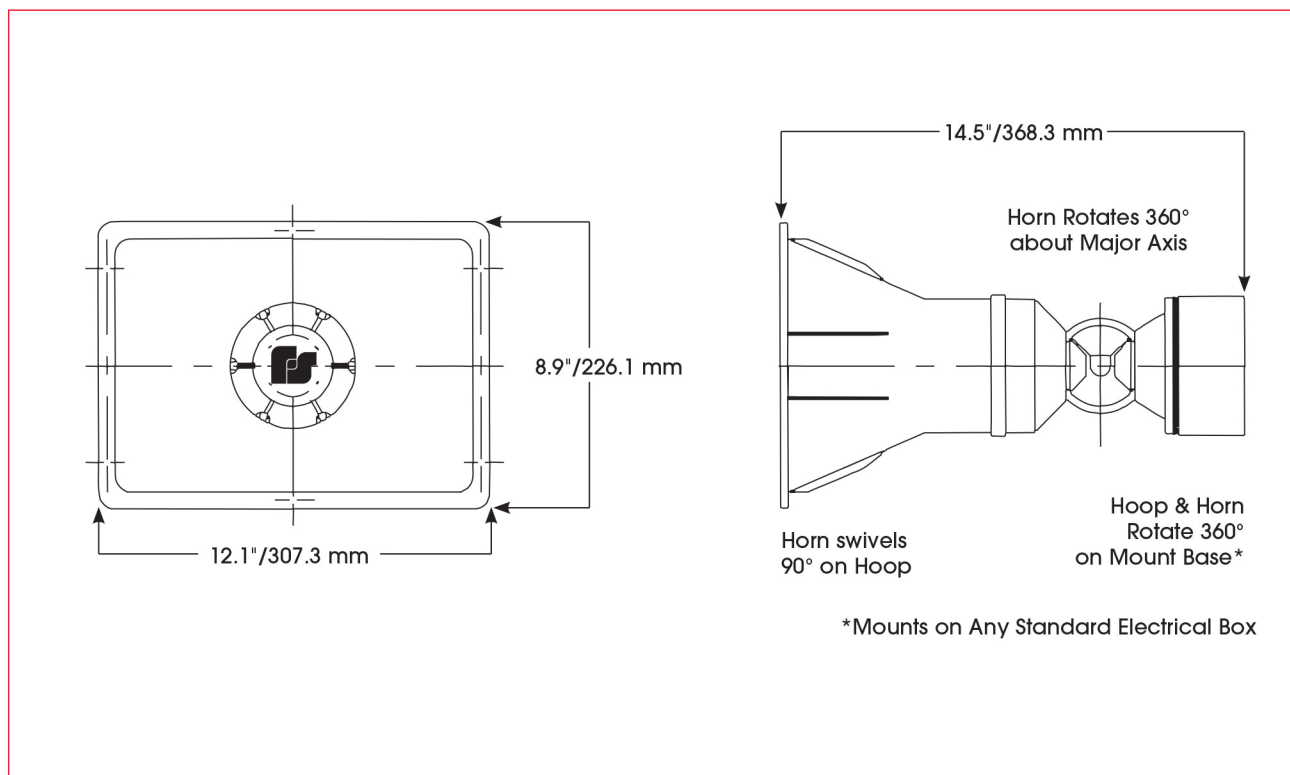

**ELECTRONIC SIREN (SST3-MV)****SPECIFICATIONS**

Operating Temperature:	-31°F to 161°F	-35°C to 72°C
Net Weight:	4.4 lbs.	2.0 kg
Shipping Weight:	5.2 lbs.	2.4 kg
Height:	14.5"	368.3 mm
Width:	12.1"	307.3 mm
Depth:	8.9"	226.1 mm
Maximum Contact Resistance	1000 Ohms	1000 Ohms

**HOW TO ORDER**

- Specify model
- Specify Accessories:  
Weatherproof Backbox (WB)

**REPLACEMENT PARTS**

<b>Description</b>	<b>Part Number</b>
Connector, 4-Position	K140340B
Adapter (Grey)	K8476121A-04
PC Board Assembly	K2005110A
Gasket	K8476122A
Speaker Assembly	K8504002A



**MICROWATT**  
Making Safety Work

Tollfree in Western Canada: 1-888-388-1592  
microwatt.com • mwsales@microwatt.com