



Vibratone® Horns

Model 350WB

DESIGNED FOR ROUTINE SIGNALING USES

- Available in 120VAC and 240VAC
- Effective range 200 feet
- Coded or sustained tones
- Wall mount
- Produces 100dBA @ 10' (110dBA @ 1m)
- Type 4X, IP65 enclosure
- UL and cUL Listed, CSA Certified and FM Approved

The Model 350WB (AC current) Vibratone® horn produces sound by the electro-mechanical vibration of a stainless steel diaphragm. The horn mechanism with diaphragm is attached to the grille. Indoor or outdoor use is made possible by the water- and dust-tight backbox.

The 350WB is available in 120 or 240VAC for 50/60Hz. The sound output level is 100dBA nominal at ten feet (110dBA @ 1m).

Model 350WB features a die-cast aluminum rear housing sealed with a gray enamel finish. The rugged outer housing resists vandalism without reducing sound output. Model 350WB is fused and utilizes a terminal block connection. The horn and backbox combination is UL and cUL Listed, CSA Certified and FM Approved.

Capable of reproducing coded blasts or sustained tones, Federal Signal's Vibratone horns are excellent for general alarm, start/dismissal, coded paging and process control signaling in areas where their sound output exceeds ambient noise levels. Compact size and various installation options make them ideal for institutional use.

Model	Voltage	Operating Current	Decibels @	
			10'	1m
350WB-120	120VAC 50/60Hz	0.18 amps	100	110
350WB-240	240VAC 50/60Hz	0.09 amps	100	110



VIBRATONE® HORN (350WB)

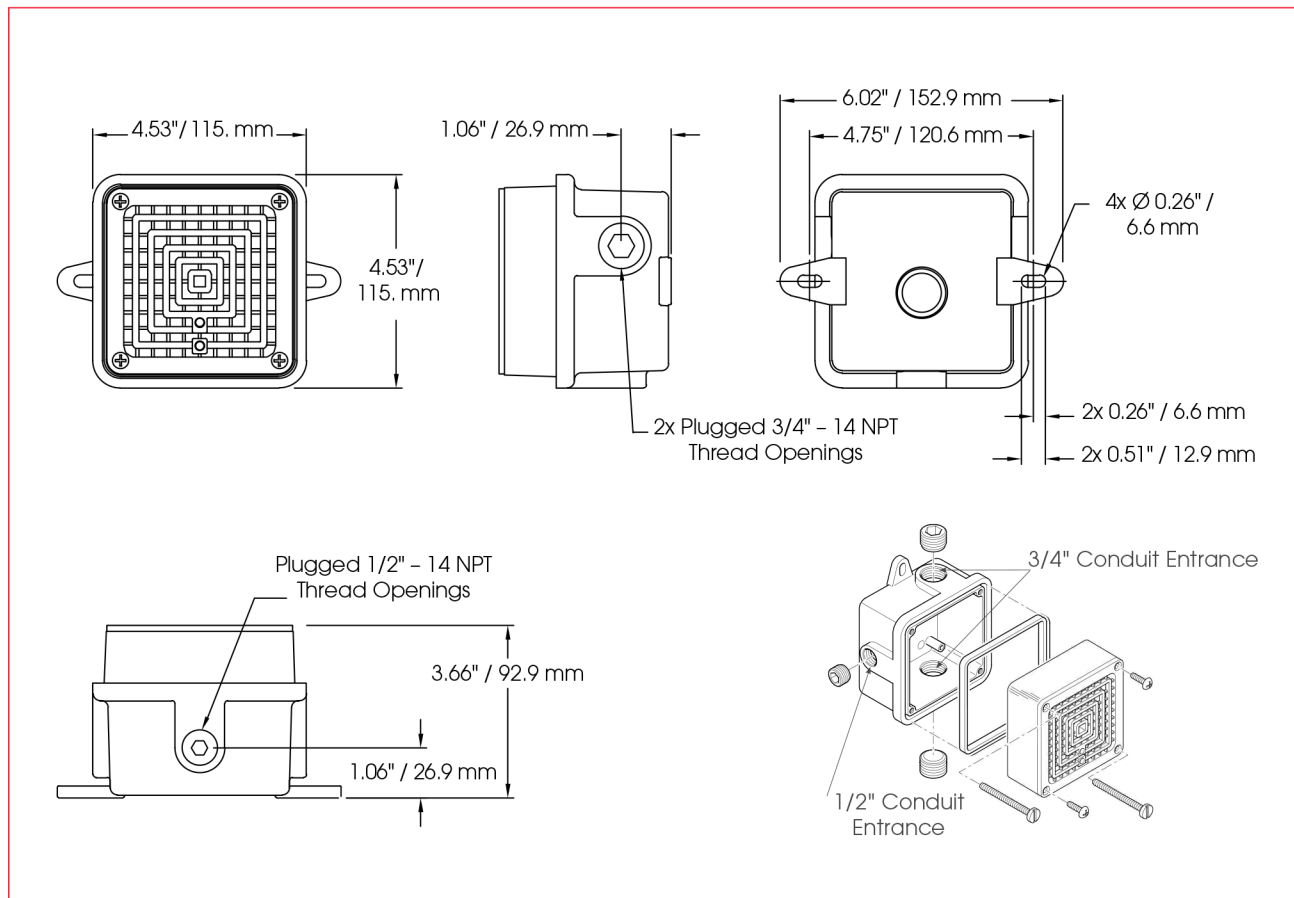

SPECIFICATIONS

Operating Temperature:	-65°F to 150°F	-54°C to 66°C
Net Weight:	2.7 lbs.	1.2 kg
Shipping Weight:	2.8 lbs.	1.2 kg
Height:	5.3"	134.6 mm
Width:	5.3"	134.6 mm
Depth:	3.66"	92.9 mm

HOW TO ORDER

- Specify model and voltage



Tollfree in Western Canada: 1-888-388-1592
microwatt.com • mwsales@microwatt.com

ACCESSORIES

PR	Projector which concentrates sound into a basic area when attached to the basic model 350/450 units; 4" H x 4" W x 6" D; shipping weight 1 lb. (0.45 kg)
PR2	Double projector directs sounds to both sides when attached to the basic model 350/450 units; ideal for use in hallways; 4" H x 11½" W x 4" D; shipping weight 2 lbs. (0.91 kg)

REPLACEMENT PARTS

<i>Description</i>	<i>Part Number</i>
Volume Control Kit	K8435663B
Coil, 120VAC (350 Horn only)	KFC1516C